

Innovative Technology

POWERING TRANSACTIONS AND INTERACTIONS

NV4000 Range User Manual

Document Revision - v.2

Exported on 29/04/2026

Change History

Version	Date	Comment
2	24 Sep 2025	Corrected PSU lower threshold & added guidance on note ownership during different parts of transactions
1	09 Sep 2025	Initial Release

 Uncontrolled Document Once Exported.
Please visit the [Support Hub](#) for the latest Information.

Table of Contents

- [NV4000 Range Product Information](#)
- [NV4000 Range Technical Data](#)
- [NV4000 Range Mechanical Installation](#)
- [NV4000 Range Software Installation and Configuration](#)
- [NV4000 Range Protocols and Interfacing](#)
- [NV4000 Range Service Guide](#)
- [NV4000 Range Approvals](#)
- [NV4000 Range Product Compliance](#)
- [NV4000 Range Appendix](#)
- [NV4000 Range Disclaimer and Safety Information](#)

NV4000 Range Product Information

Contents

- [General Description](#)
 - [Key Features](#)
 - [Typical Applications](#)
 - [Component Overview](#)
 - [NV200 Spectral Options](#)
 - [NV200 Spectral Bezel Options](#)
 - [Cashbox Options](#)
 - [Module Options](#)
 - [BNF Options](#)
-

General Description

The NV4000 is a highly secure and technologically advanced banknote validator and multiple denomination recycler built upon ITL's market leading NV200 Spectral technology. State of the art spectral sensors offer complete note image capture by scanning over 4.8 million data points to authenticate the validity of notes. The unit boasts 99%+ first time acceptance of new and street grade notes with a note to note processing time of 2 seconds.

The unit contains a number of security features including optical and mechanical anti-strimming technology that delivers outstanding fraud protection. The NV200 Spectral's cutting-edge note straightening mechanism, together with 4-way barcode acceptance bring the user exceptional note handling and increased ticket acceptance rates.

The NV4000 has 4 single denomination recycling drums as well as a 400 mixed denomination replenishment cassette that can either be used to refill the recycling drums or as a direct payment. With spray payout and note-to-note dispense times less than 2s the NV4000 provides market leading speed in class.



NOTE: The replenishment cassette performs discrimination on staff verified notes.

Key Features

- 100% note image capture - 4.8 million data points
 - 99%+ first time acceptance of new & street grade notes
 - Stained note detection
 - 2 second note to note processing
 - Modular design – 1 – 4 modules & additional replenishment cassette
 - 280 note capacity + 400 note loader
 - High level API provided to aid integration
-

Typical Applications

The NV200 Spectral validator can be used in a variety of situations where high security and high-volume bank note acceptance and validation are needed. Some typical applications are:

- Kiosks
 - Casino redemption points
 - Retail environment such as POS Systems
-

Component Overview



Single Note Feed

Cashbox Options



1000n Cashbox



Recycler Options





Module Options



NV200 Spectral Options

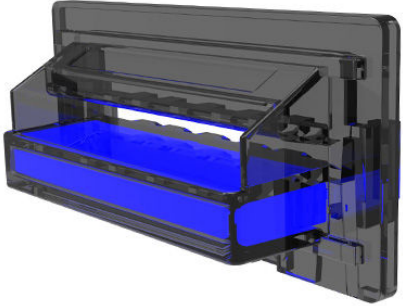

ITL Part Numbers	Description	Image
SR02005	NV200 Spectral Head	 A black, rectangular NV200 Spectral Head with a red top cover and a red circular component on the front.
PA03269	NV200 Spectral with UAP  Compatible for use with PA03120 Bunch Note Feeder only.	 A black NV200 Spectral with UAP, featuring a red top cover and a red circular component on the front, with a feeder mechanism attached to the bottom.

NV200 Spectral Bezel Options

ITL Part Numbers	Description	Image
PA00610	Standard Bezel (85mm)	
PA00639	Metal Bezel	



ITL Part Numbers	Description	Image
PA01038	Self-Aligning Bezel (White)	
PA02053	Self-Aligning Bezel (Black)	

ITL Part Numbers	Description	Image
PA04224	Coin Resistant Metal Bezel	
PA03039	Bezel Assembly NV4000 Interface	

ITL Part Numbers	Description	Image
PM02976	<p>Blanking Plate Interface</p> <p> For use with PA03048 NV4000 Interface when paying out from the bezel or BNF.</p>	



Cashbox Options

 Some national currencies differ in thickness and circulation practices. Depending on usage, this can impact cash box capacities by 10-15%. Consult with your ITL representative for more details.

ITL Part Number	Description	Image
PA03849	<p>1000 Note Cashbox Inner</p> <p> Compatible with PA02739 Chassis only.</p>	

ITL Part Number	Description	Image
PA02739	<p>500/1000 Note Cashbox Chassis</p> <p> Compatible with PA03849 Cashbox only.</p>	
PA03109	<p>2200 Note Cashbox Inner</p> <p> Compatible with PA03296 Chassis only.</p> <p>Cannot be used with Replenishment Cassette option.</p>	
PA03296	<p>2200 Cashbox Chassis</p> <p> Compatible with PA03109 Cashbox only.</p> <p>Cannot be used with Replenishment Cassette option.</p>	



Module Options



ITL Part Number	Description	Image
PA03048	NV4000 Interface	 A black, rectangular electronic module with a red front panel and a red latch on the right side. It has several ports and connectors on the top surface.
PA03271	Recycler Assembly	 A black, rectangular assembly with a red top cover. The top cover has a handle and a label with diagrams. It has a circular opening on the front and a latch on the side.

ITL Part Number	Description	Image
<p>PA03057</p>	<p>Conveyor Housing Assembly</p> <div data-bbox="394 288 710 443" style="background-color: #e6e6fa; padding: 5px;"> <p> PA03040 Conveyor Included.</p> </div>	
<p>PA03040</p>	<p>Conveyor</p>	

ITL Part Number	Description	Image
PA03492	Replenishment Dock	
PA03493	Replenishment Cassette Assembly	

BNF Options

ITL Part Number	Description	Image
PA03120	<p data-bbox="555 304 772 331">Bunch Note Feeder</p> <p data-bbox="355 376 975 517"> = Requires PA03269 NV200 Spectral with UAP PM02976 Interface Blanking Plate required as you are unable to use PA03039 Bezel Assembly NV4000 Interface. </p>	
PA04354	<p data-bbox="507 719 820 745">BNF Customer Facing Bezel</p> <p data-bbox="355 790 879 817"> = Compatible with Bunch Note Feeder only. </p>	
PA04360	<p data-bbox="539 1133 788 1160">BNF Back Office Bezel</p> <p data-bbox="355 1205 879 1232"> = Compatible with Bunch Note Feeder only. </p>	
PM02790	<p data-bbox="539 1547 788 1574">BNF Vertical Bezel Lid</p> <p data-bbox="355 1619 951 1682"> = Compatible with PA04360 BNF Back Office Bezel only. </p>	

ITL Part Number	Description	Image
PM02792	<p data-bbox="571 241 756 271">BNF Bezel Outer</p> <div data-bbox="320 286 1007 412"><p data-bbox="355 315 951 376"> Compatible with PA04360 BNF Back Office Bezel only.</p></div>	 A black, rectangular plastic bezel with a central cutout and mounting tabs on the sides.

NV4000 Range Technical Data

Contents

- Dimensions
- Weight
 - Standard Unit - No Cashbox
 - Cashbox Options
 - Module Options
- Environmental Requirements
 - Operation
 - Storage
- Power Requirements
 - Supply Voltages
 - Supply Currents
 - Power Supply Guidance
- Interface Logic Levels
- Reliability Data
- Media Requirements
 - Minimum and Maximum dimensions for IN via NV200 Spectral
 - Minimum and Maximum dimensions for IN via Replenishment Cassette
 - Minimum and Maximum dimensions for notes to Recyclers
 - Note Quality Guidelines
 - Replenishment Cassette Note Guidelines

Dimensions

The dimensions below are for the NV4000, 1000n cashbox with 4 recyclers and the replenishment cassette. Other cashbox / module options will change the dimensions.

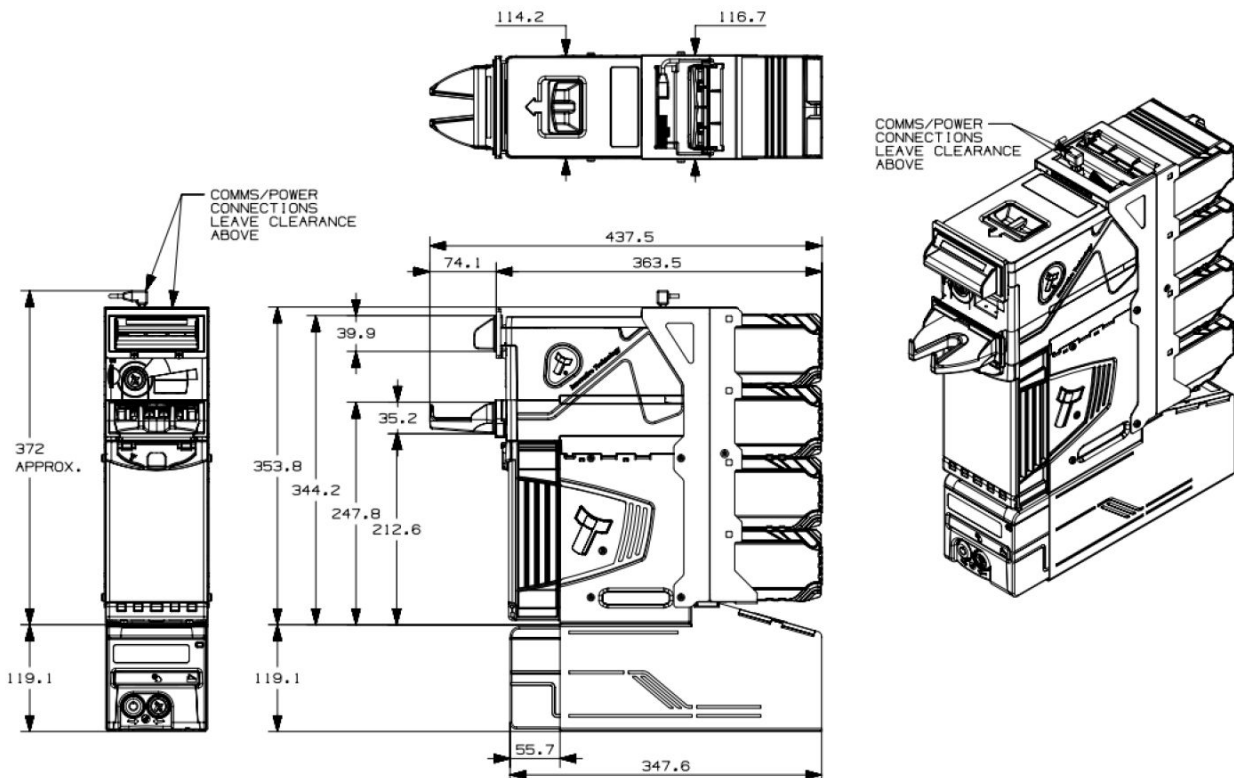

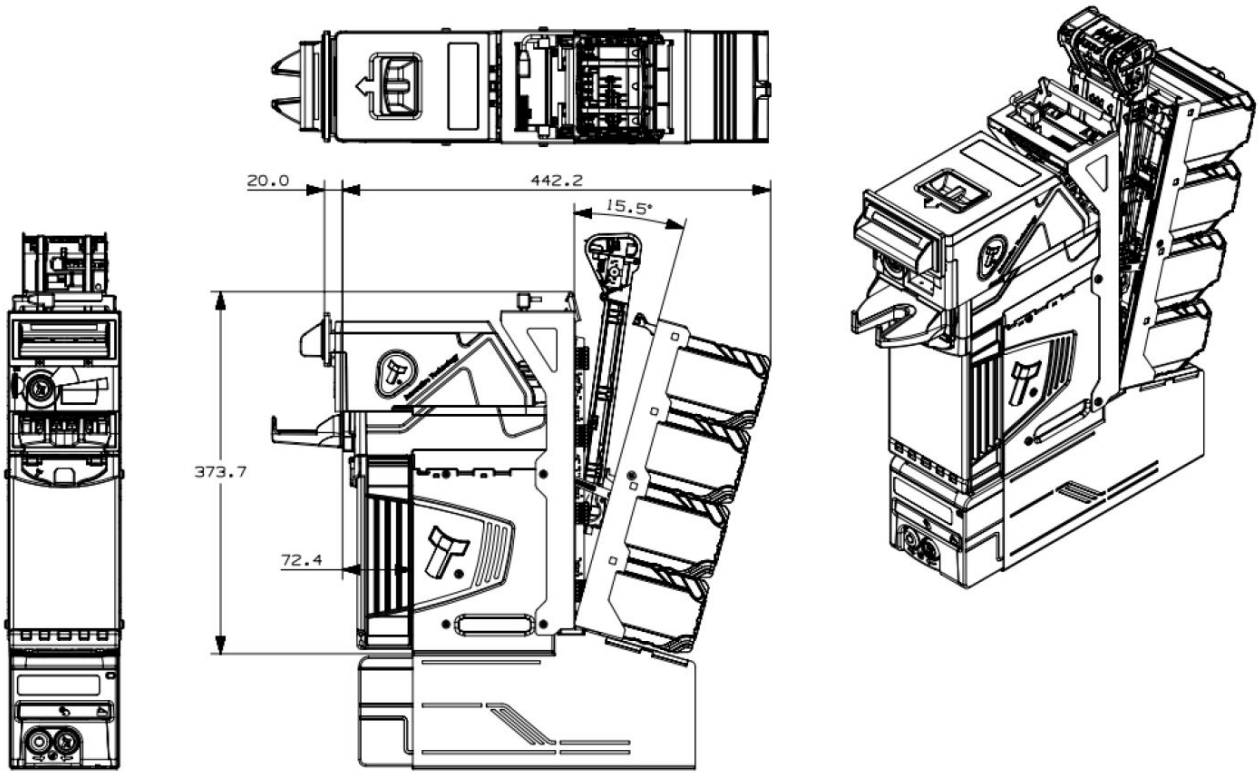

The dimensions below are for the same configuration but with a BNF. For dimensional drawings of other configurations contact support@innovative-technology.co.uk

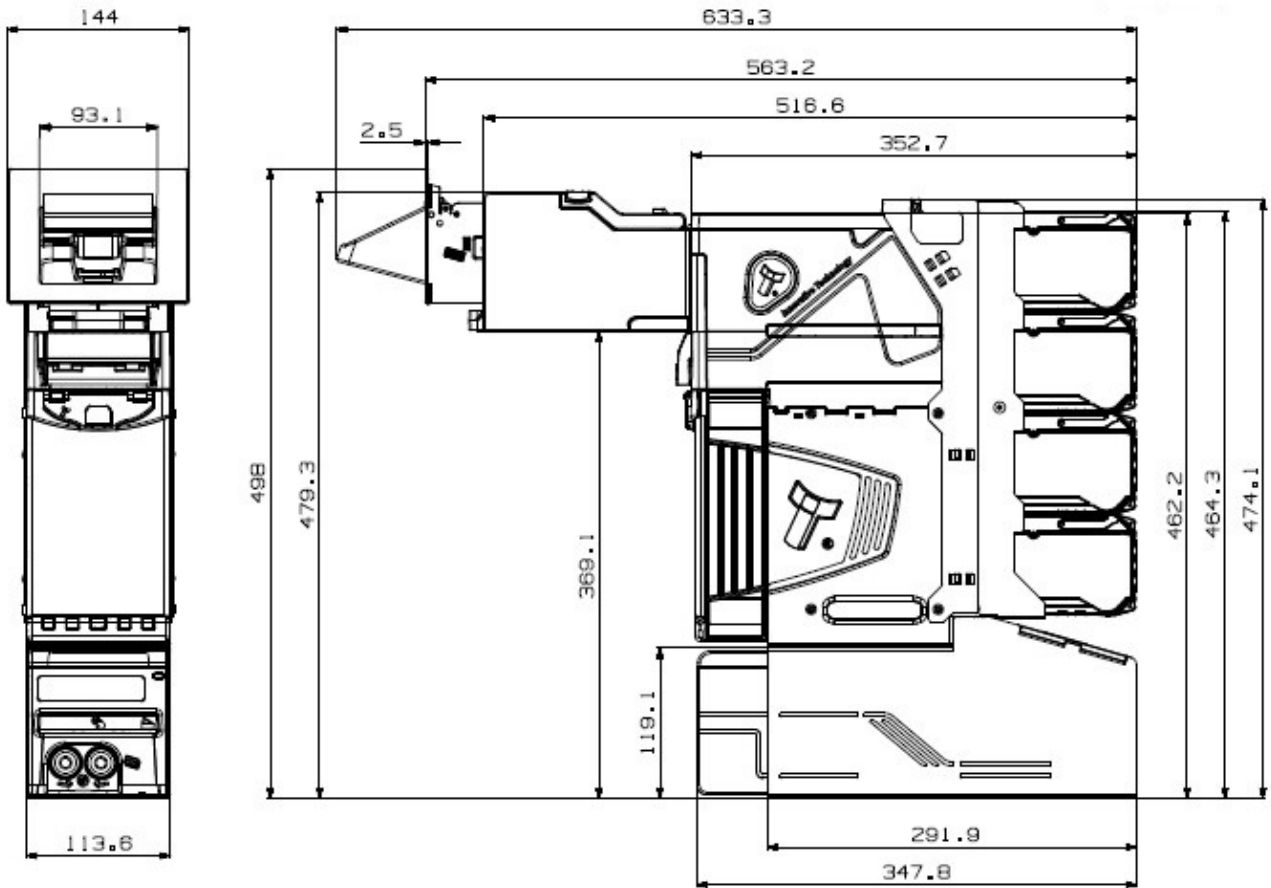

Weight

The tables below show the weights for the individual components of the product.

For example, and NV200 Spectral with Standard Bezel and 500 Note Cashbox with Chassis would weigh 3.21Kg (1.20 Kg + 2.01 Kg)

Standard Unit - No Cashbox

Unit	Weight Empty	Weight Full
NV200 Spectral - Standard Bezel	1.20kg	N/A

Cashbox Options

Unit	Weight Empty	Weight Full
1000 Note Cashbox and Chassis	2.19kg	3.09kg

Module Options

Unit	Weight Empty	Weight Full
Recycler Module	0.52kg	0.58kg
Conveyor	0.39kg	N/A
Interface	0.60kg	N/A
Replenishment Cassette	3.28kg	3.64kg

Environmental Requirements

Operation

Environment	Minimum	Maximum
Temperature	+3°C	+50°C
Humidity	5%	95% Non-condensing

Storage

Environment	Minimum	Maximum
Temperature	0°C	+60°C
Humidity	5%	95% Non-condensing



Transitioning from storage to operational temperatures should be done no faster than 2°C per hour.

Power Requirements

Supply Voltages

Supply Voltage	Minimum	Nominal	Maximum
Supply Voltage (VDC)	+21.6VDC	+24VDC	+26.4VDC
Supply Ripple Voltage	0V	0V	0.25V @ 100 Hz

Supply Currents

The supply current required to run the NV200 Spectral will vary during the phases of operation, the maximum current the device can draw is 7A.

Power Supply Guidance

Check the power requirements of the host machine and other peripherals to dimension a suitable power environment for the machine setup.

The unit shall be supplied from a source specified as Electrical Energy Source Class 1 (ES1) to IEC/UL 62368-1, or specified as SELV according to IEC/UL 60950-1

TDK Lambda manufactures suitable power supplies. See table below for further details.

Power Supply Unit	Specification	RS Stock Code	Farnell Stock Code
TDK Lambda RWS-300B-24	+24VDC / 12.5A	813-9128	2419997

Interface Logic Levels

Interface Logic Levels	Logic Low	Logic High
Inputs	0v to +0.5V	+3.7V to +12V
Outputs with 2K2Ω pull-up resistor	+0.6V	Pull-up voltage of host interface
Maximum Current Sink	50mA per Output	

Reliability Data

Below is an explanation outlining the Mean Cycles Between Failure (MCBF) & Mean Cycles Between Interruption (MCBI) for the NV200 Spectral. Where a cycle is defined as a note/ticket either stacked, stored or paid-out. An example is if £20 is accepted and a £10 paid out that would be classed as 2 cycles.

The difference between MCBF and MCBI is that a failure is classed as an event which will require a service call – e.g. unit is seeing poor acceptance. Whereas an interruption is an event which store/site staff could rectify without a trained engineer present – e.g. clearing a note path jam.

The target MCBI / MCBF figures are listed below:

MCBI: 25,000

MCBF: 100,000

Media Requirements

The NV200 Spectral is capable of handling multiple denominations simultaneously, the media that can be accepted includes, but is not limited to:-

- Paper notes
- Polymer notes
- Windowed notes
- Barcoded tickets

Minimum and Maximum dimensions for IN via NV200 Spectral

	Minimum	Maximum
Length	110mm	165mm
Width	60mm	85mm

Minimum and Maximum dimensions for IN via Replenishment Cassette

	Minimum	Maximum
Length	110mm	165mm
Width	60mm	79mm

Minimum and Maximum dimensions for notes to Recyclers

	Minimum	Maximum
Length	110mm	165mm
Width	60mm	82mm

Note Quality Guidelines

When loading notes in through the validator or the replenishment cassette, ensure that notes are in good condition and are stacked neatly together to ensure optimum performance:



Do not load any of the following notes into the validator, this may cause poor performance or malfunction:

Damaged Notes



Taped Notes



Folded Notes



Torn Notes



Wet Notes



Inserting any of the notes above can cause jams or notes to be left unprocessed

Replenishment Cassette Note Guidelines

The replenishment cassette is a multi-denomination discriminator capable of distinguishing between the banknotes contained within the main currency classifier. All notes inserted into it are presumed to be both **genuine** and **fit**.

Depending on the size of some banknotes they may not fit in the replenishment cassette - for example Euro 100p1, 200p1 and 500p1 are too wide. Instead the attendant should only insert the p2 versions of these notes. Details of the dimensional requirements can be found in the Media Requirements above.

NV4000 Range Mechanical Installation

Contents

- Bezel Mounting
 - Cashbox Removal & Opening
- Lock Mounting
 - Lock Specification
 - Lock Cam
 - NV200 Spectral
 - Cashbox
 - Replenishment Cassette
- Earth Bonding
- Screw Specification
- Things to Consider

Bezel Mounting

Open Note Path

Pull the top latch in the direction shown to unlock the note path



Open Upper Note Path

When the note path has unlocked, lift the upper part to give clear access to the front



Attach Bezel Cable

Plug the bezel cable into the connection socket on the front. Ensure that the tab on the connector aligns with the notch on the socket



Insert Bezel

Slide the bezel down into the slots on the front of the bezel

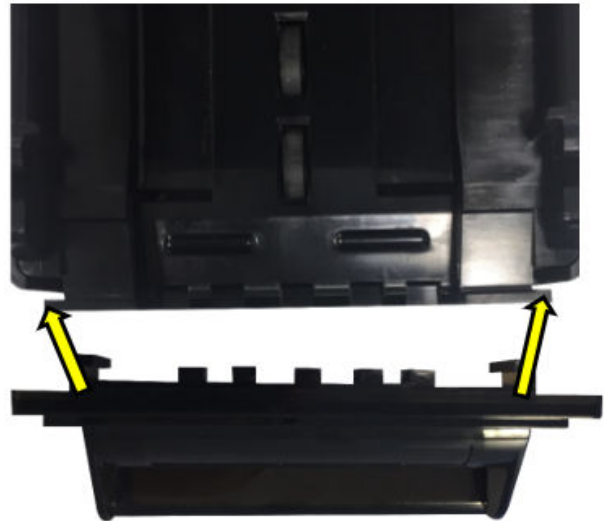

Close Note Path

Push the upper note path back down until you hear it click firmly back into place



Cashbox Removal & Opening

NV200 Spectral

The image to the right shows the NV200 Spectral with 1000 note cashbox



Cashbox Handle

Pull the cashbox handle forward, this will unlatch the cashbox, allowing it to be slid forward from the chassis



Slide Cashbox Forward

Continue to pull the handle forward, sliding the cashbox completely free from the chassis



Turn Cashbox Over

To access the cash, turn the cashbox as the door is on the bottom



Open Cashbox

Push the black door latch in and lift the door at the same time



Lock Mounting

Lock Specification

Locks for the NV200 Spectral are available from Innovative Technology Ltd.
ITL Part Number: [PA00650](#)

There is also a keyless lock assembly available, this comes as standard on the 1000 note cashbox.
ITL Part Number: PA02713

The conveyor lock is an available option from Conveyor revision 2.

ITL Part Number: PA04419

There are various lock manufacturers and distributors. Refer to NV4000 Range Appendix for lock specification.

Lock Cam

The following Lock Cams are included with the product.

NV200 Spectral Lock Cam Part Number: PM00614

Cashbox Lock Cam Part Number: [MC00247](#)

Conveyor Lock Cam Part Number: MC03056

NV200 Spectral

Lock Location

The Lock can be fitted to the front of the NV200 Spectral replacing the red front insert (shown to the right) which ships by default



Remove head from chassis

Before the lock can be installed, remove the NV200 Spectral from the cashbox chassis. Lift the latch, slide the head forward and lift the head away from the chassis

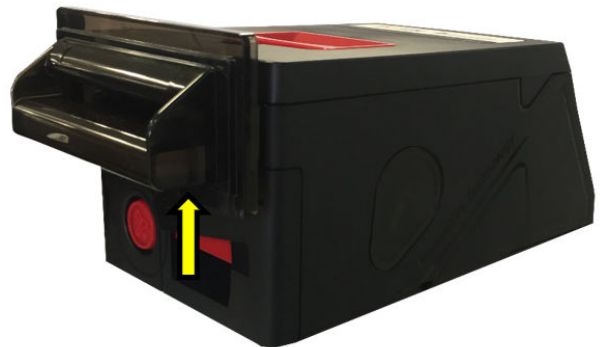

Remove red insert

There are 2xT8 screws located on the underside of the NV200 Spectral, remove those and lift away the plastic insert

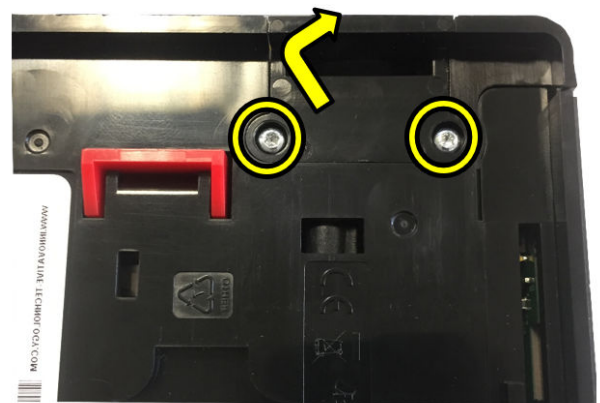

Remove Locking Cam

Press the plastic clip together and remove the locking cam



Remove Plastic Insert

To remove the plastic insert, from the lock mount, press the two clips on the side together and push through. Insert the cam lock in its place



Re-attach Locking Cam

Re-attach the locking cam onto the barrel of the lock and tighten



Fit Assembled Lock

To fit the assembled lock into the unit, place the bottom in first then push the top into position



Screw in place

Turn the unit upside down and screw in the 2xT8 screws previously removed

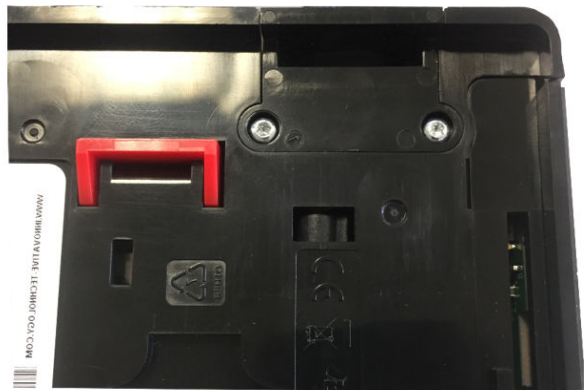

Cashbox

Cashbox Lock Location

The standard NV200 Spectral cashbox can be fitted with 2 locks for security. These are located on the bottom of the cashbox on the hinged door



Remove Blanking Plates and Fit Lock

Similarly, to fitting a lock on the front of the NV200 Spectral remove the locking cam and blanking plate which is there by default and replace with the desired lock

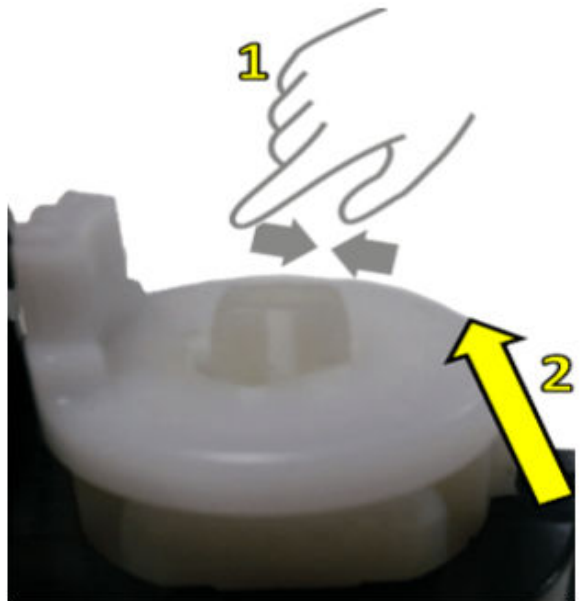

Finish Installation

With the lock in place add the washer and the locking cam

- Ensure when the keylock is turned the locking cam is inserted in the same position it was previously removed otherwise it can cause interference.

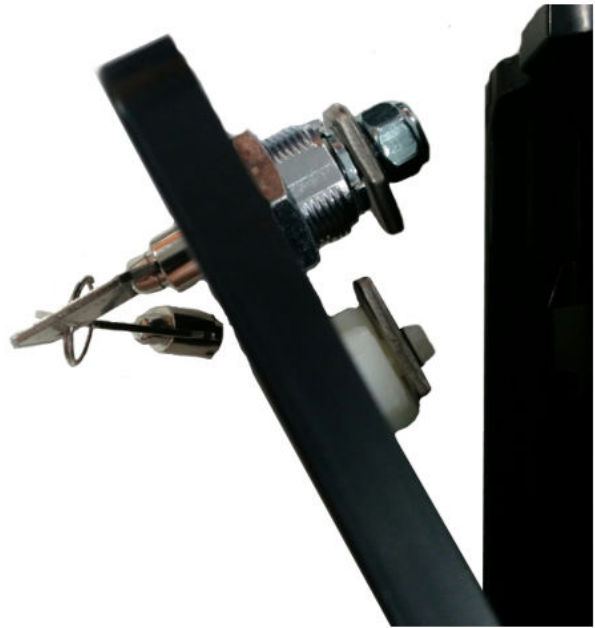

Replenishment Cassette

Please visit the [Support Hub](#) for the video.

Earth Bonding

It is very important that the NV200 Spectral is properly bonded to earth, using one of the earth tabs. Earthing on the standard chassis can be affixed to the lower screw mounting points at the side of the unit:



If you are using a replenishment cassette the 4 mounting holes on the bottom of the cassette can be used.

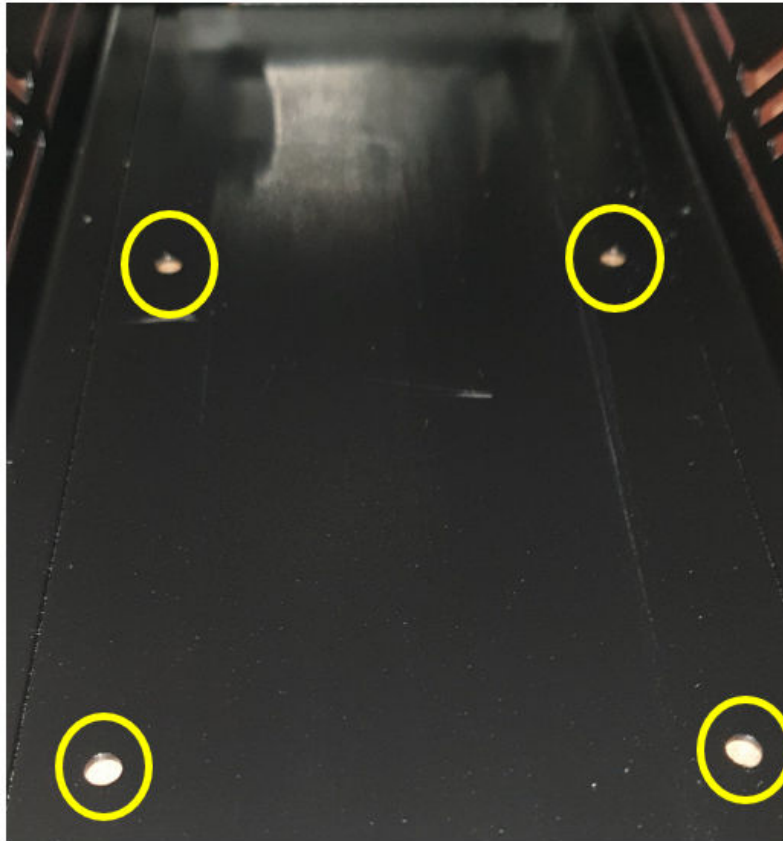

The resistance between the chassis and Earth should be less than 0.7Ω.



Lack of proper earth bonding causes failures!

Screw Specification

The scope of delivery does not include screws for machine mounting. See table below for screw specification reference.

Location	Thread Type	Screw Length
Bezel	M3	12mm
Cashbox	M4	6mm

Things to Consider

When mounting an NV4000 there are several things to consider including:

- Weight of a fully loaded unit as defined in the [Technical Data](#).
- Accessibility – allow enough space to reach all connectors, switches and to allow access should clearing a jam be required. Details of which can be found in the [Technical Data](#).
- Cable management – ensure no connectors are damaged/removed from everyday use.
- Visibility of the top bank of LED's help to identify an error with the device.

NV4000 Range Software Installation and Configuration

Contents

- [Introduction](#)
 - [Software Downloads](#)
 - [Drivers](#)
 - [Dataset/Firmware Programming](#)
 - [Validator Manager](#)
 - [SD Card](#)
 - [Remote Updates](#)
-

Introduction

The NV4000 leaves the factory programmed with the latest dataset and firmware files, unless specifically requested. However, it is important to ensure your device is kept up to date with the latest dataset and firmware. This section will give you a brief overview of the various update possibilities with the NV4000. For detailed instructions refer to the relevant manual package supplied with the software or contact support@innovative-technology.co.uk

Software Downloads

All software from Innovative Technology Ltd is free of charge and can be downloaded from the website once registered and logged in. If you are not registered, create an account via the Create an account form. A confirmation email will be sent to the registered email address once all contact details have been successfully submitted.

Drivers

The ITL drivers allow you to connect any of our validators to a compatible Windows device. If you are connecting via an IF17 then you will not need to follow this process as they are signed Microsoft Drivers and should install automatically. If this isn't the case or your computer is disconnected from the network, there is a standalone package included within the driver downloads.

Dataset/Firmware Programming

Validator Manager

General Description

Validator Manager is a utility which allows the user to reprogram any of ITL's validators, hoppers as well as coin and note recycler. Note that admin rights are required during installation. The validator must be in SSP for the Validator Manager to detect the device.

System Requirements

- Microsoft Windows 8.1 and above
- .Net Framework 4.5 and above
- 256mb ram
- 50mb hard disk free
- Connected NV200 Spectral with active com port



We have seen instances where one of the dll's (itdata1.dll) used in Validator Manager are flagged as a Trojan, this is a false positive and if this happens you will need to add a rule to your antivirus to allow the file to run.

Hardware Setup

The connection example below shows a direct USB connection between the NV200 Spectral and the host machine (PC). For other connection examples see NV4000 Setup Examples in [NV4000 Range Protocols and Interfacing](#).

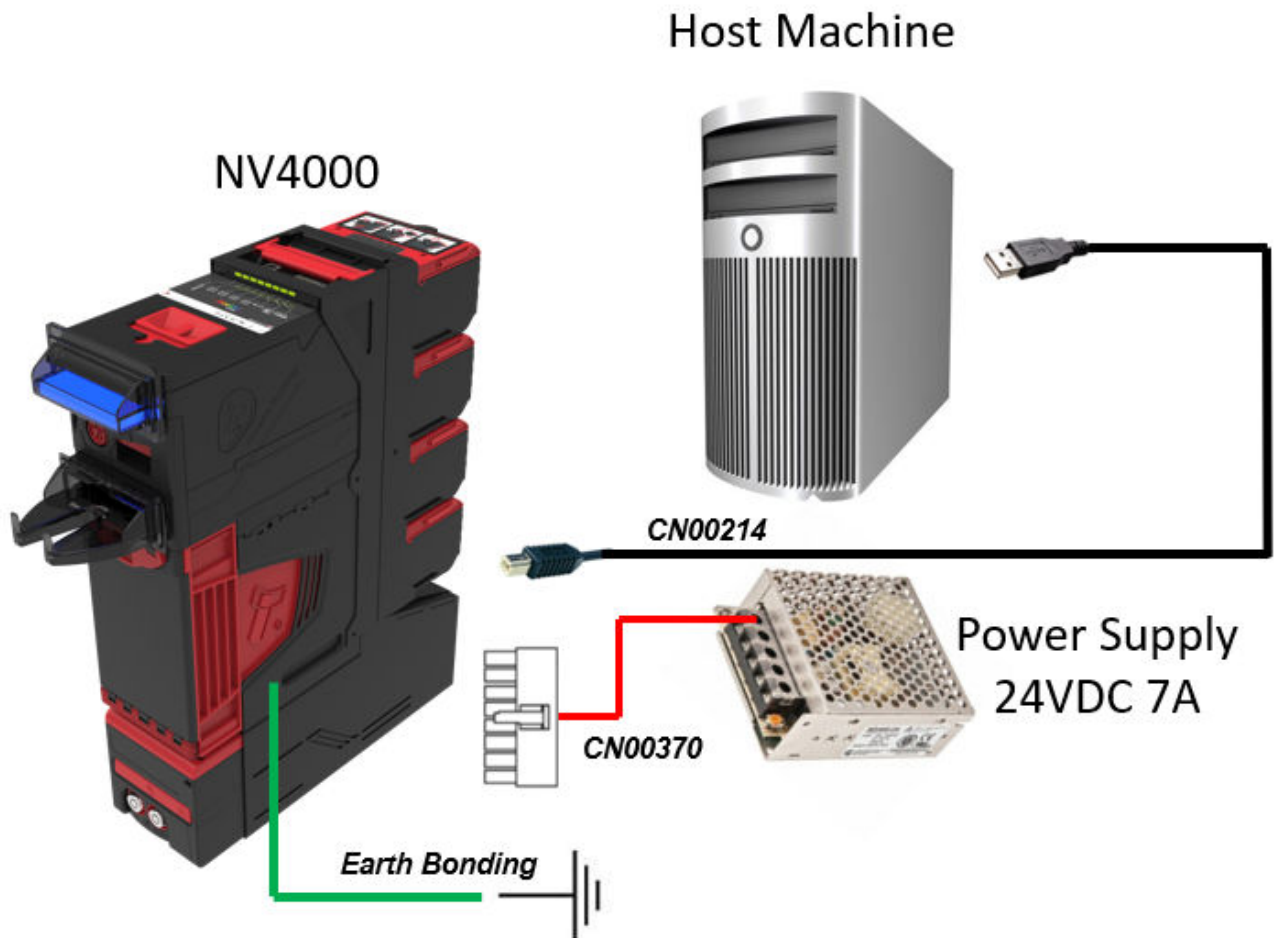



Programming the Device

Open Validator Manager and click detect devices. This will scan all active com ports for a unit, if the NV4000 fails to connect ensure the correct drivers are installed and the unit is in SSP.

By selecting the Program tab, you can reprogram the NV4000. To begin the upload, click open file, then browse to the file location (usually Downloads) before clicking OK.

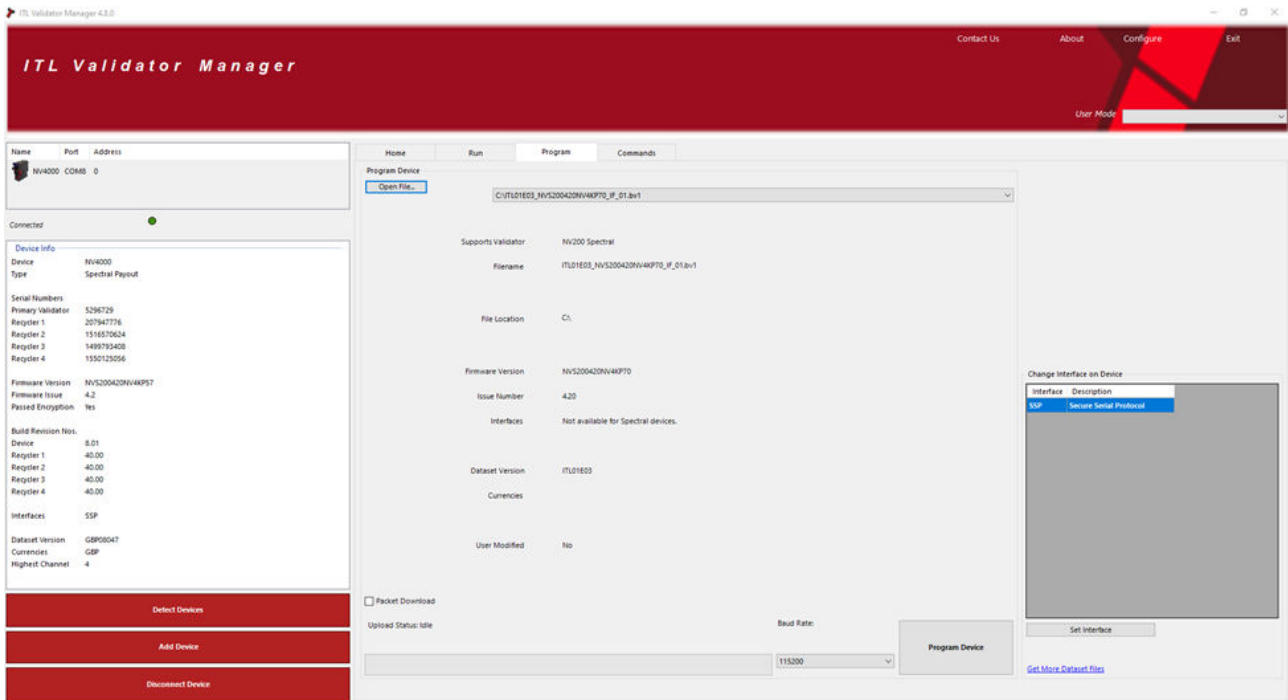
Once the file has been selected its information will be populated and the Program device tab will become active. Finally, hit 'Program Device', the unit's bezel will now begin to flash signalling the update has begun. When completed the unit will restart and a pop-up box will appear saying Device Programming Complete.



 Interrupting the download process can result in the unit entering a non-functional state, once the process has started it cannot be halted.

SD Card

General Description

The NV4000 can also be reprogrammed through the SD slot on the front of the unit. To do this the SD card must be correctly formatted and meet the hardware requirements defined below.

Hardware Requirements

The SD card must meet the following hardware requirements:

Minimum: 4GB – Class 10

Maximum: 32GB – Class 10

The following SD card has been tested and recommended for best performance: <https://www.sandisk.co.uk/home/memory-cards/sd-cards/ultra-sd>

Re-programming via SD Card

Follow the steps below to set up the SD card and perform the update:

Connect the SD card to your PC using an SD card reader.

Ensure that the card is FAT-32 formatted and is blank.

Create a folder on the SD card called nv200hs.

 This must be lowercase.

Inside the folder, place the dataset file that you want to load on to the validator. Datasets can be downloaded from the Innovative Technology website.

Ensure the NV200 Spectral is powered on and has booted up.

Insert the SD card into the slot on the front. The bezel will now start flashing.



Do not unplug the validator during the update process.

Wait until the bezel lights solid green. When it does, the SD card can be removed.

After the SD card has been removed, the unit will reboot. This takes around 10 seconds. Once it has rebooted the unit will begin updating the NV4000 modules.

Remote Updates

General Description

The unit can be updated through an SSP command which sets the validator into an update mode before downloading the firmware file. Details of how this process is implemented can be found in the SSP Implementation Guide. ITL also provide some example applications to assist in integrating this into host machine software.



This is a complex operation and failure to implement correctly may damage units.

NV4000 Range Protocols and Interfacing

Contents

- [Introduction](#)
- [Interface Connectors](#)
 - [Pinout](#)
- [User Interfaces](#)
 - [NV200 Spectral Dip Switches](#)
- [SSP and eSSP](#)
 - [General Description](#)
 - [Pin Assignments](#)
 - [Setup Examples](#)
 - [NV4000 USB Connection](#)
 - [Power Requirements](#)
 - [NV4000 TTL Connection](#)
 - [Power Requirements](#)
 - [NV4000 And Smart Coin System](#)
 - [Power Requirements](#)

Introduction

The NV4000 supports SSP which is a proprietary low level protocol developed by Innovative Technology. We provide a high level API that allows for easy integration into your host machine software. This has been developed on .Net Core to ensure cross platform support. Details of which can be obtained from support@innovative-technology.com

Interface Connectors

The NV4000 uses a 16-pin Molex 0039012165 connector for power and TTL, RS-232 & Opto-isolated interfacing. The connector is located on top of the NV4000 along with a USB B connector.



Power is always required on pins 15(+V) and 16(0V) of the 16-way connector regardless of connection type.

Pinout



The USB connector is a standard Type 'B' USB socket which can be used for communication – a shielded USB 2.0 compliant Type 'A' to 'B' lead can be used to do this.

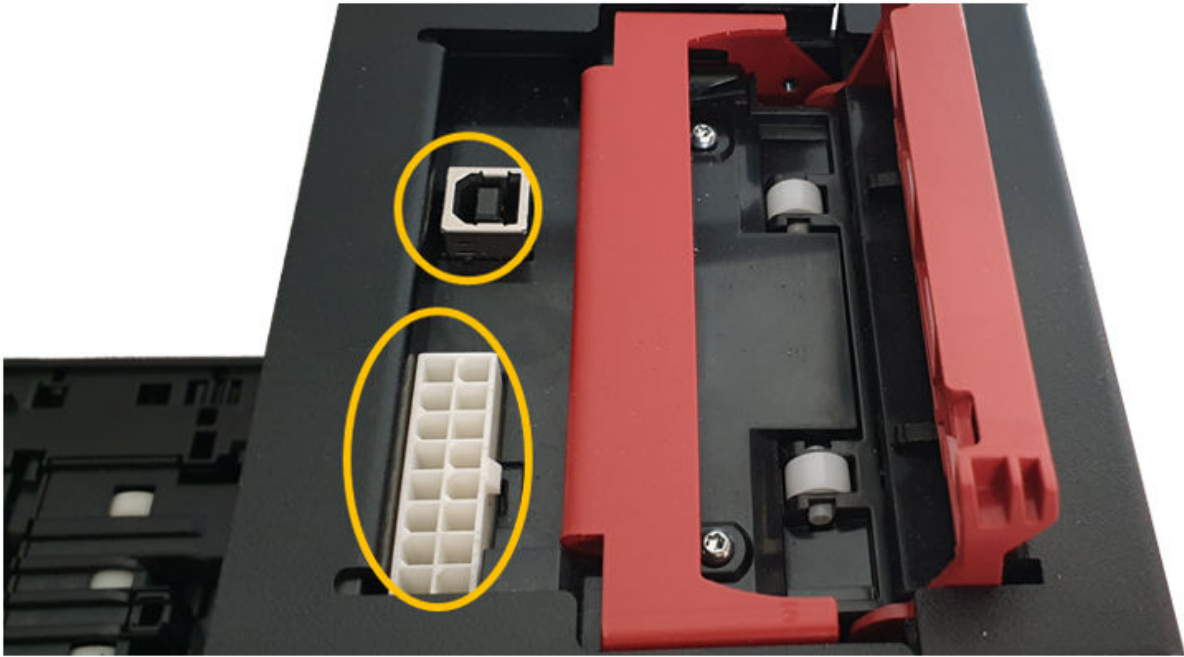

User Interfaces

NV200 Spectral Dip Switches

The NV200 Spectral has a Dual Inline Package (DIP) switch bank that is used to set the various options for the unit. A summary of the switch options is shown below:

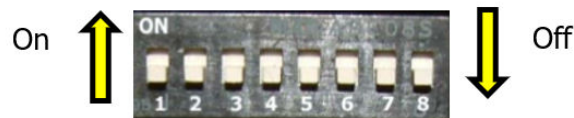

Switch	Option	Switch OFF	Switch ON	Default Setting
1	Disable Barcode	Read Enabled	Read Disabled	OFF
2	Channel 1 Inhibit	Channel Enabled	Channel Disabled	OFF
3	Channel 2 Inhibit	Channel Enabled	Channel Disabled	OFF
4	Channel 3 Inhibit	Channel Enabled	Channel Disabled	OFF
5	Channel 4 Inhibit	Channel Enabled	Channel Disabled	OFF
6	Channel 5 Inhibit	Channel Enabled	Channel Disabled	OFF
7	Channel 6 Inhibit	Channel Enabled	Channel Disabled	OFF
8	Protocol Select	Switches between the primary (selected) protocol and SSP (used for Programming). The switch needs to be toggled ON and OFF to alternate between the two. This will cause the unit to reset.		OFF

SSP and eSSP

General Description

Smiley[®] Secure Protocol (SSP) and Encrypted Smiley[®] Secure Protocol (eSSP) are field proven secure interfaces specifically designed by Innovative Technology Ltd. to address the problems by cash handling systems. Problems such as acceptor swapping, re-programming acceptors and line tapping are all addressed. This interface is recommended for all new designs. Innovative Technology Ltd. provides a full REST API package upon request. This can be used on Windows, Linux and Android. Contact support@innovative-technology.co.uk for further information.

Pin Assignments



Pin	Name	Type	Description
1	TxD TTL	Output	Serial Data Out (Tx)
3	TxD RS232	Output	Serial Data Out (Tx)
5	RxD TTL	Input	Serial Data In (Rx)
11	RxD RS232	Input	Serial Data In (Rx)
15	+Vin	Power	24VDC Supply
16	0V	Power	0V Supply (GND)



+24VDC and 0V (GND) must always be connected, also when using USB connections.

Setup Examples

The drawings below highlight how to connect the NV200 Spectral to an SSP host machine using available cables and interfaces from Innovative Technology Ltd. For cable drawings refer to NV4000 Range Appendix

NV4000 USB Connection

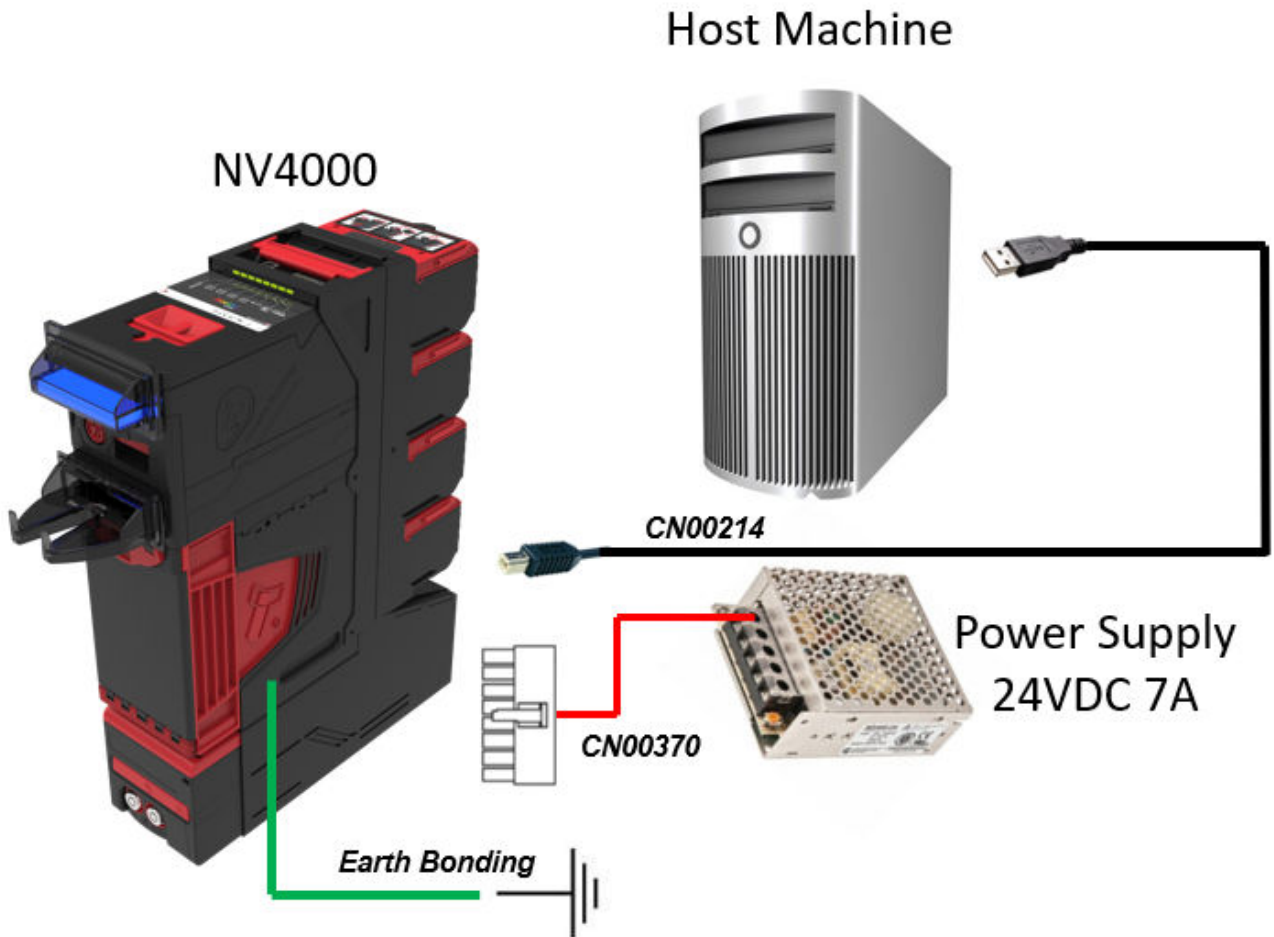

Part	Description	Quantity
NV4000	NV4000 Bank Note Recycler	1
CN00370	Payout Power Only	1
CN00214	USB A to B Cable	1

Power Requirements

This setup option requires a stable 24VDC / 7A power supply.

Check the power requirements of your host machine and other peripherals to dimension a proper power environment for your system setup.



It is very important that the Cashbox Chassis of the NV4000 is bonded to earth, as lack of proper bonding can cause communication issues and failures. The earth bond on a NV4000 should be made to the intended connection on the Cashbox Chassis. The resistance between the NV4000 and the Earth pin on the mains plug should be less than 0.7 Ohms.

NV4000 TTL Connection

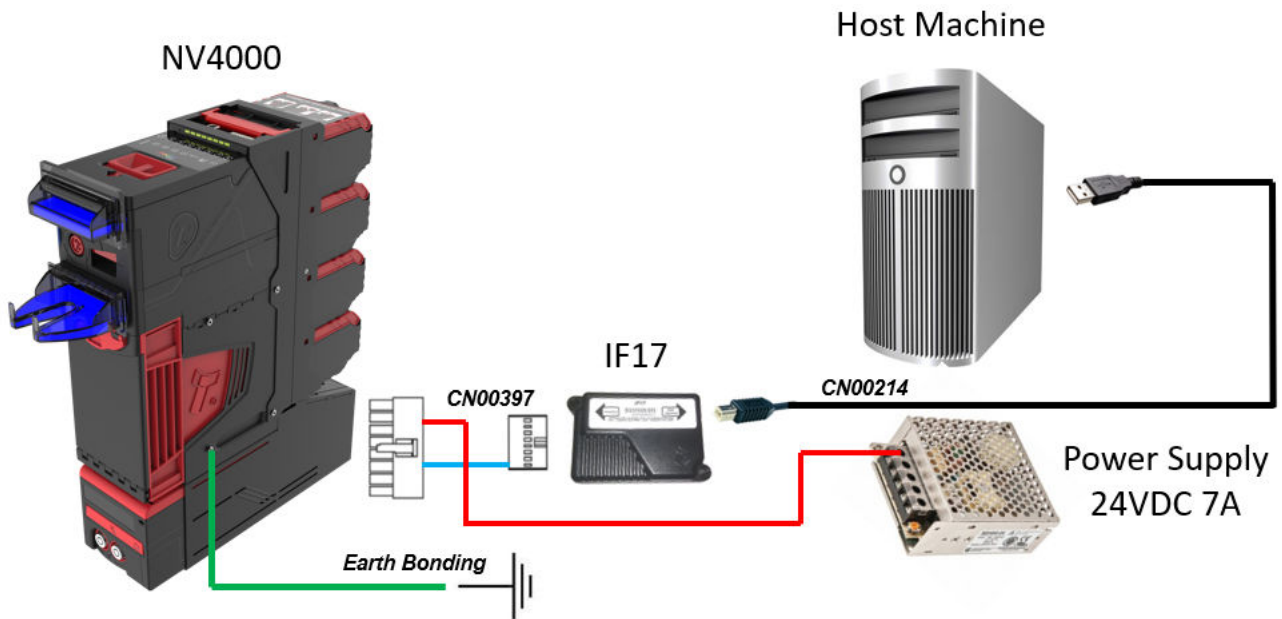

Part	Description	Quantity
NV4000	NV4000	1
IF17	USB Interface Converter	1
CN00397	SMART Payout to Host Assembly	1
CN00214	USB A to B Cable Assembly	1

Power Requirements

This setup option requires a stable 24VDC / 7A power supply.

Check the power requirements of your host machine and other peripherals to dimension a proper power environment for your system setup.

- It is very important that the Cashbox Chassis of the NV4000 is bonded to earth, as lack of proper bonding can cause communication issues and failures. The earth bond on a NV4000 should be made to the intended connection on the Cashbox Chassis. The resistance between the NV4000 and the Earth pin on the mains plug should be less than 0.7 Ohms.

NV4000 And Smart Coin System

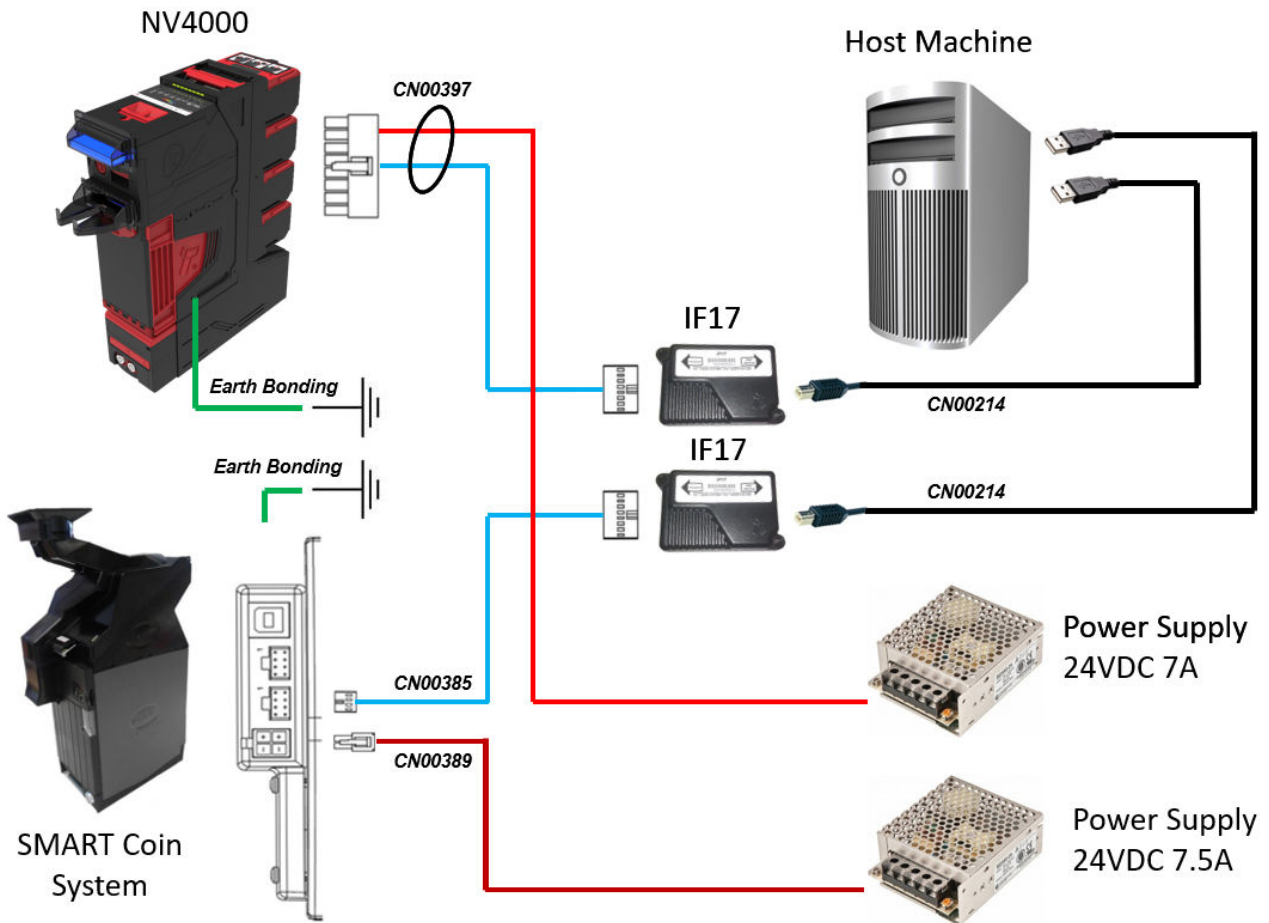

Part	Description	Quantity
NV4000	NV4000	1
SCS	Smart Coin System	1
IF17	USB Interface Converter	2
CN00389	SMART Hopper Power Cable	1
CN00397	Spectral Payout Duel SSP to Host Cable	1
CN00385	SMART Hopper SSP user interface cable	1
CN00214	USB A to B Cable Assembly	2

Power Requirements

This setup option requires a stable 24VDC / 7A power supply for the NV4000 whilst the SCS requires 24V DC 7.5A according to the product specification.

Check the power requirements of your host machine and other peripherals to dimension a proper power environment for your system setup.



It is very important that the Cashbox Chassis of the NV4000 is bonded to earth, as lack of proper bonding can cause communication issues and failures. The earth bond on a NV4000 should be made to the intended connection on the Cashbox Chassis. The resistance between the NV4000 and the Earth pin on the mains plug should be less than 0.7 Ohms.

NV4000 Range Service Guide

Contents

- Routine Maintenance
 - Introduction
 - Recommended Cleaning Intervals
 - Cleaning the NV4000
 - Cleaning the Validator
 - Bezel/Status LED Flash Codes
 - NV4000 Module Flash Codes
 - NV4000 Flash Codes
 - Conveyor Module
 - Recycler (1-4) Module
 - Interface
 - Replenishment Cassette
 - Recycler (1-4) Modules while Replenishing with Replenishment Cassette
 - Checking Power Connections
 - Checking the Supply Voltage
 - Communication with the Host
 - Obtaining Logs using SD Card
 - Clearing a Jam in the NV4000
 - Note is in the note path
 - Note is visible once the head has been removed
 - Note is visible once the interface has been removed
 - Note isn't visible once the NV200 Spectral has been removed
 - Clearing a Jam from the Recyclers and Conveyor
 - Guidance on note ownership
 - Customer Facing Operations
 - During accept
 - During dispense
 - Internal Operations
 - During Float
 - During Replenish
 - Testing after an error has been cleared
-

Routine Maintenance

Introduction

The NV4000 has been designed to minimise any problems or performance variations over time. This has been achieved by careful hardware and software design; this attention to the design means there is very little user maintenance required.

Recommended Cleaning Intervals

Innovative Technology Ltd recommends cleaning the optical lenses every month or as required. Dirt, dust or other residue leads to bad note acceptance and other performance degradation. Refer to the section below for detailed cleaning instructions.



Disconnect the power **BEFORE** carrying out any cleaning operations to avoid the risk of causing damage to the validator.

DO NOT use solvent based cleaners such as alcohol, petrol, methylated spirits, white spirit or PCB cleaner. Using these solvents can cause permanent damage to the units; only use a mild detergent solution as directed below.

DO NOT attempt to disassemble the validator head. Trying to do this could cause personal injury and will damage the unit beyond repair.

Cleaning the NV4000

Cleaning the Validator

To remove the NV200 Spectral head unit, first lift the red head release catch located on the front of the NV200 Spectral.

Then, slide the head unit forward and lift it off the chassis

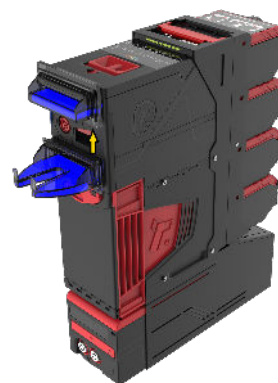

To open the note path cover, pull the top cover release latch forward (towards the bezel) and lift the cover as shown below (it is recommended to also remove the bezel to allow correct cleaning of the note path guides).



The note path is visible and can be cleaned. Carefully wipe the surfaces with a soft lint free cloth that has been dampened (NOT wet) with a water and mild detergent solution (e.g. household washing up liquid) - be very careful when cleaning around the sensor lenses and make sure they are clean and dry before closing the cover and powering the unit.



Do not use any lubricants.

Do not lubricate any of the note transport mechanism or any part of the note path, as this can affect the operation of the validator.

Bezel/Status LED Flash Codes

The NV200 Spectral Validator has inbuilt fault detection facilities. If there is a configuration or other error, the NV200 Spectral front bezel will flash in a particular sequence, and a summary of the Bezel Flash Codes for the NV200 Spectral is shown below:

Flashes		Indicated Status / Error	Recommended Action
Red	Blue		
1	1	Note Path Open	Close the lid of the NV200 Spectral validator it will click into place as it shuts.
	2	Note Path Jam	<ol style="list-style-type: none"> 1. Power down the NV200 Spectral. 2. Open the NV200 Spectral using the red catch on top and inspect the note path for any note debris. 3. If there isn't any evidence of a note carefully remove the NV200 Spectral from the base using the red catch on the front. 4. A note could be just sticking out from the cashbox, remove power and the NV200 Spectral head. 5. If a note is visible remove the note. 6. Re-attach the head and power.
	3	Unit Not Initialised	The NV200 Spectral will need to be returned to your nearest repair centre for repair.
2	1	Cashbox Removed	Insert the cashbox, on the NV4000 the interface checks the cashbox sensor so if the issue persists please re-dock the interface.
	2	Cashbox Jam	Remove the jam from inside the cashbox.
3	1	Firmware Checksum Error	There has been an issue with the attempted download, retry the download with the recovery section on validator manager, if this fails arrange for the unit to be returned to the nearest repair centre; details of which can be found on our website.

	2	Interface Checksum Error	The firmware loaded doesn't contain the primary interface from the previous firmware. Download with the IF file containing the correct protocol.
	3	EEPROM Checksum Error	There has been an issue with the attempted download, retry the download with the recovery section on validator manager, if this fails arrange for the unit to be returned to the nearest repair centre; details of which can be found on our website.
	4	Dataset Checksum Error	
4	1	Power Supply too Low	Check the voltage on your power supply is within the specified voltage range as outlined in Power Requirements in NV4000 Range Technical Data If the voltage appears to be correct, check to ensure the power supply voltage doesn't vary by more than 10% under minimum current draw.
	2	Power Supply too High	Check the voltage on your power supply is within the specified voltage range as outlined in Power Requirements in NV4000 Range Technical Data If the voltage appears to be correct, check to ensure the power supply voltage doesn't vary by more than 10% over maximum current draw.
	3	Card Format	The data card inserted is incorrect, re-format the card.
	4	Payout Reset	The Recycler Modules are in the process of resetting, wait for it to recover.
5	1	Firmware Mismatch	The Firmware on the device connected doesn't match the firmware on the NV200 Spectral. Ensure the Firmware supports the connected device.
	2	Recycler Jam	The NV4000 has encountered an issue and a note has jammed, follow the steps as described in Clearing a Jam from the Recyclers and Conveyor .
	4	Payout Jam recovery in progress	The NV4000 encountered a payout jam and is attempting to recover. 5 notes will be moved to the cashbox, from the recycler. Once the unit has completed this it will go back in service.
	5	Safe Interface not Detected	the connection to the safe interface module. Also check the Cashbox Type flag currently set on the device.

NV4000 Module Flash Codes

Each additional module for the NV4000 has its own flash codes, outlined in the subsections below.

NV4000 Flash Codes

The NV4000 has a bank of 8 LED's to correspond with each peripheral, the label on the NV200 Spectral shows which LED relates to which device (as shown below):

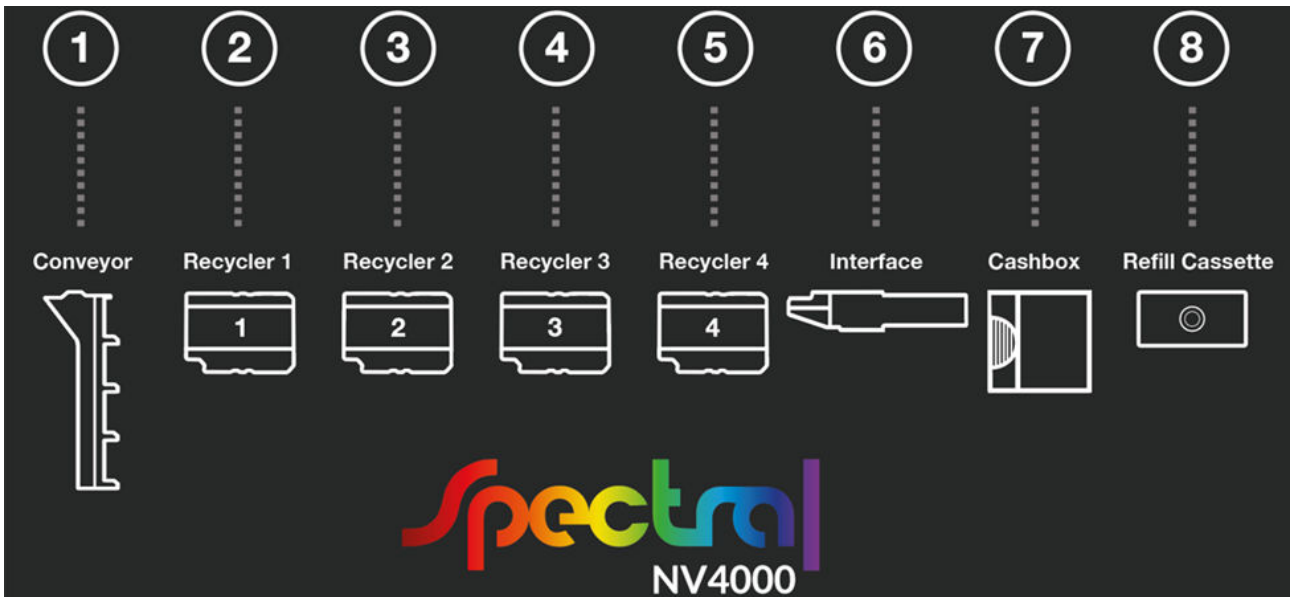

If the peripheral is detected the LED illuminates, if it is off the device is not present.

The error flashes for the modules are as follows:

Conveyor Module

Green LED	Red LED	Orange LED	Description of Error
		Flashing	Device Starting Up
Solid			Device in Service
Flashing			Device in operation
	1	1	Conveyor Open
		2	Belt Missing
		3	Payout Failure
		4	Pay-in Failure
		5	Diverter Failure
		6	Waiting for Validator
	2	1	Belt failed to move
		2-4	Internal Comms

Green LED	Red LED	Orange LED	Description of Error
	3	1-6	Calibration Error
	4	1-6	(Reserved)

Recycler (1-4) Module

Green LED	Red LED	Orange LED	Description of Error
		Flashing	Device Starting Up
Solid			Device in Service
Flashing			Device in operation
	1	1	Pay-out Failure
		2	Pay-in Failure
		3	Empty Failure
		4	Accountancy Error
		5	Note Edge not Seen
		6	EEPROM Error
		7-8	Note Movement Error
	2	1-5	Tape Error
	3	1-2	Calibration Error

Interface

Green LED	Red LED	Orange LED	Description of Error
		Flashing	Device Starting Up
Solid			Device in Service
Flashing			Device in operation
	1	1	Diverter Failure

Green LED	Red LED	Orange LED	Description of Error
		2	LED failure
		3	Stacker position failure
		4	Stacker run timeout
		5	Note in the interface
		6	Stacker full
		7	Cashbox removed
	2	1-4	Motor error
	3	1-5	Calibration error

Replenishment Cassette

Green LED	Red LED	Orange LED	Description of Error
		Flashing	Device Starting Up
Solid			Device in Service
Flashing			Device in Operation
	1	1	Dock lid open
		2	Cassette Removed
		3	Dock Un-initialised
		4	Dock entry calibration error
		5	Dock exit calibration error
		6	Validation calibration error
		7	Dataset checksum error
	2	8	EEPROM checksum error
		1	Handle open

Green LED	Red LED	Orange LED	Description of Error
		2	Tray full
		3	Cassette initialisation error
		4	Cassette pay-in calibration
		5	Cassette reject calibration
	3	1	Dock Jam
		2	Cassette Jam
		3	Conveyor Jam
		8	Error during Replenish

Recycler (1-4) Modules while Replenishing with Replenishment Cassette

Green LED	Red LED	Orange LED	Description of Error
		Flashing	Device Starting Up
Solid			Device in Service
Flashing			Device in operation
	1	1	Lid open
		2	Cassette removed
		3	Uninitialized
		4	Entry calibration
		5	Exit calibration
		6	Service hatch Open
	2	1	Handle open
		2	Tray not empty
		3	Initialisation error

Green LED	Red LED	Orange LED	Description of Error
		4	Pay in calibration
		5	Reject calibration
	3	1	Dock Jam
		2	Cassette Jam
		3	Conveyor Jam

Checking Power Connections

Check to ensure the power cables are correctly connected to the unit.

Checking the Supply Voltage

If the power supply seems to be powered and connections to the unit are in place, yet the unit isn't powered, check the voltage output from the power supply is sufficient and the polarity is correct. If this isn't the issue replace the cable as it may have been damaged. Should this not resolve the issue, contact your local repair centre, details of which can be found on our website.

Communication with the Host

If there is no communication with the host check the communication cable, typically this will be the IF17 and the port on the host system.

Ensure the cable is connected to the IF17 correctly, so the connectors are fully seated, and the USB cable is connected to the computer.



If the unit is connected, enter Windows Device Manager and check the active com ports, there should be a device labelled as USB Serial Port. If no com port is present replace the IF17 and a new device will register.

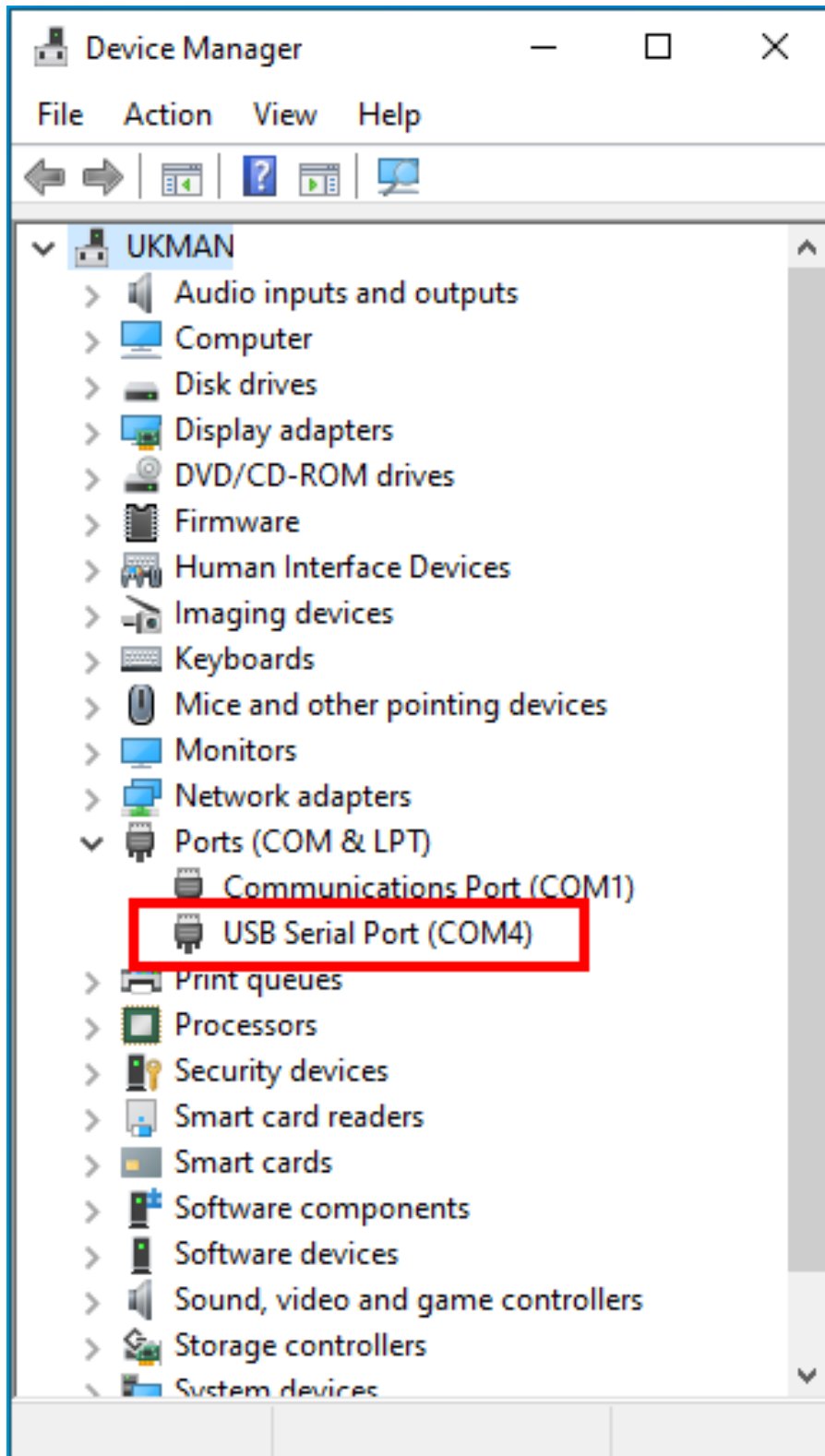

Check the connection to the host software, if there is still an issue replace the IF17 or switch com ports on the PC. If the unit is detected but there is a yellow triangle next to the serial port, then the drivers should be reinstalled.

For Linux use the `dmesg` console command as shown below:

```
File Edit View Search Terminal Help
james@james-VirtualBox ~ $ dmesg | grep tty
[ 0.000000] console [tty0] enabled
[ 55.387744] usb 1-2: FTDI USB Serial Device converter now attached to ttyUSB0
james@james-VirtualBox ~ $
```

Obtaining Logs using SD Card

The NV200 Spectral has 128MB internal memory which is used to capture event and performance logs. To retrieve the logs from the internal memory, you can insert an SD card into the front slot. The SD card must be FAT-32 formatted and have an empty folder on there called **NV200SL**. When this card is inserted the bezel will flash alternating colours, when it goes green the data transfer is complete and the SD card can be removed.

Alternatively, you can put an SD card in the slot that has two empty folders on it: **hsdata** and **valaudit**. This SD card will log all future events but does not extract logs currently stored on the internal memory. If this card is inserted all logs will be written to it instead of the internal memory. This is ideal for “live” logging.

 You can insert a completely blank card (still formatted for FAT-32) and it will automatically populate the empty folders listed above and grab the internal log file. Please wait for the bezel to turn green to indicate that it has completed the extraction process.

See Hardware Requirements under SD Card in [NV4000 Range Software Installation and Configuration](#) for the hardware requirements for the SD Card.

Clearing a Jam in the NV4000

As explained earlier the LED's on top of the NV4000 will help guide you where there is an error with the device.

If the bezel is flashing 1R2B indicating a note path jam, this indicates it's not made it's way into the recycling side of the device, so the note can be:

- Solely in the NV200 Spectral head
- In between the NV200 Spectral head and the interface
- Between the interface and the cashbox

 Warning if there is a note jammed caution should be used when removing devices to prevent further damage to the note

Note is in the note path

If the note is jammed in the note path it is possible to clear the jam by lifting the latch at the front and carefully pulling the device towards you, once free of the NV4000 pull the head release catch as shown below. Once the note path is clear you can then carefully pull the note out of the unit. Now shut the head re-dock the unit and it should reinitialise.



Note is visible once the head has been removed

If you can see the note in the interface, slide the red latch forward this then allows the door to hinge up and give you access to the note path. Now slowly pull the note out and check for any debris before closing the door and re-attaching the validator.

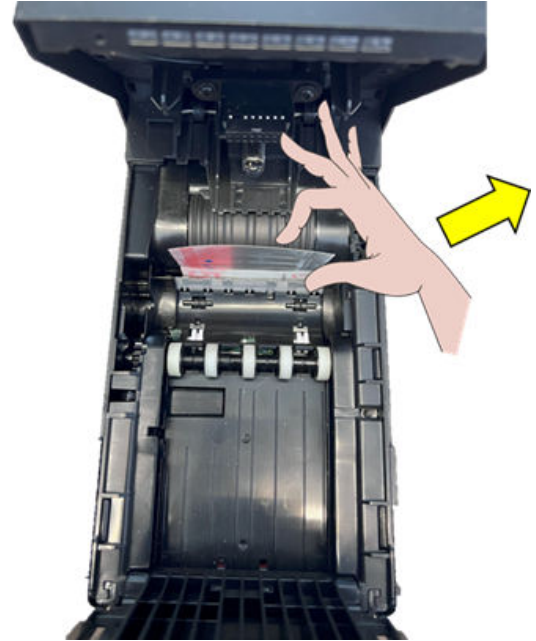

Note is visible once the interface has been removed

To clear this type of jam you will need to disconnect the power and then remove the NV200 Spectral head. Once you remove the head as explained in the picture below, check to see if the note is protruding from the cashbox. If it is, this means the note hasn't been driven down into the cashbox, this jam can be cleared by winding the drive gears on the left of the unit and slowly pulling the note out. Once the note has been removed, replace the NV200 Spectral head and reconnect the power.



Note isn't visible once the NV200 Spectral has been removed

If the note isn't visible then there is a jam in the cashbox, remove the cashbox by pulling the handle on the front of the cashbox and sliding it forward. Turn the keyless lock to release the barn door, you will now have access to the cashbox to manually remove the note. Usually the note will be resting on or underneath the stack of notes and may be folded or torn. Once the note has been identified slowly pull the note out of the unit. Replace cashbox and the unit should run through internal diagnostics and then be back in service.



Clearing a Jam from the Recyclers and Conveyor

Before accessing the conveyor and the recyclers you need to remove the NV200 Spectral head by lifting the red latch (1), then sliding forward (2).

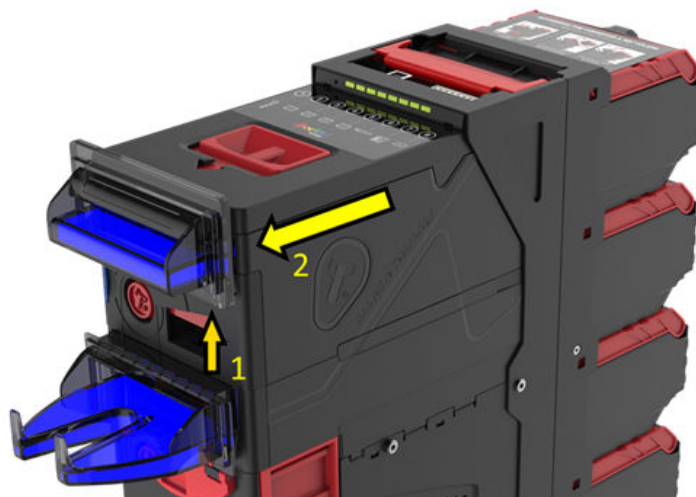

The red handles at the top can now be opened, the larger metal handle opens the conveyor and the smaller handle allows for the recyclers to be removed.

To remove the conveyor lift the metal handle (1), then the back of the NV4000 can open (2), this gives access to the conveyor which can be lifted out for cleaning or maintenance.

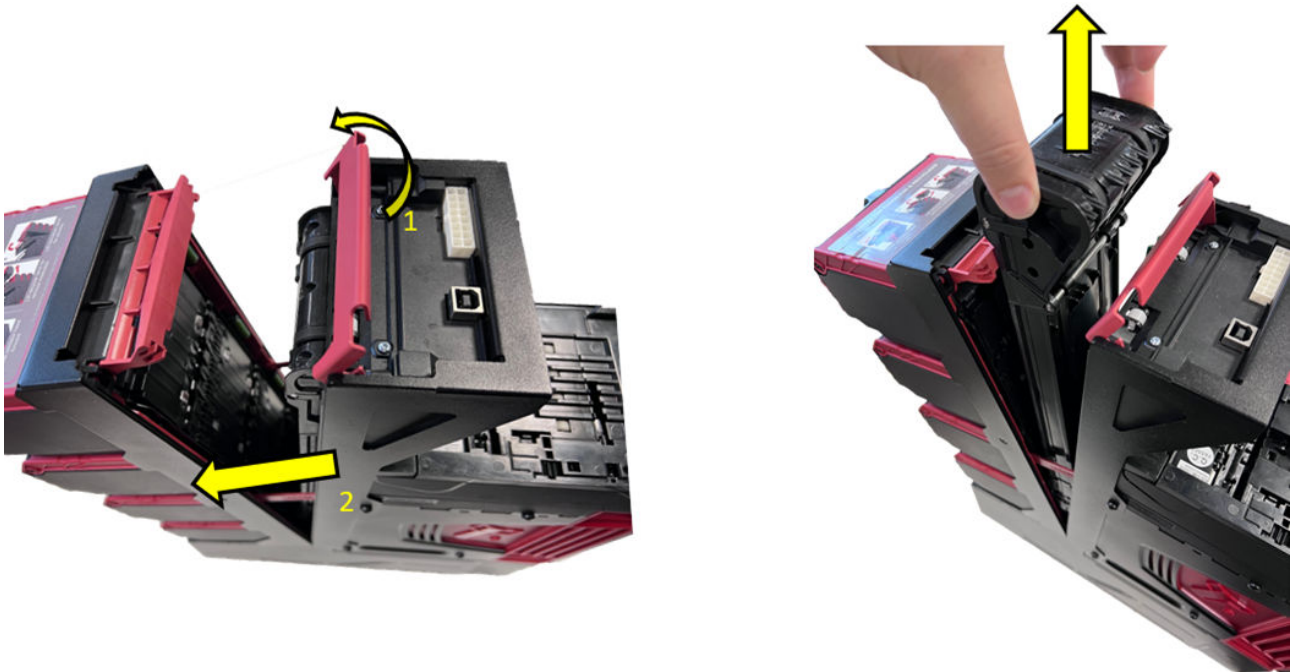

If the note has left the recyclers but not made it into the validator it will be visible when the conveyor has been removed.

If the note has jammed transferring between the recycler and the conveyor they will be in one of the positions below, depending on which recycler the note was leaving:

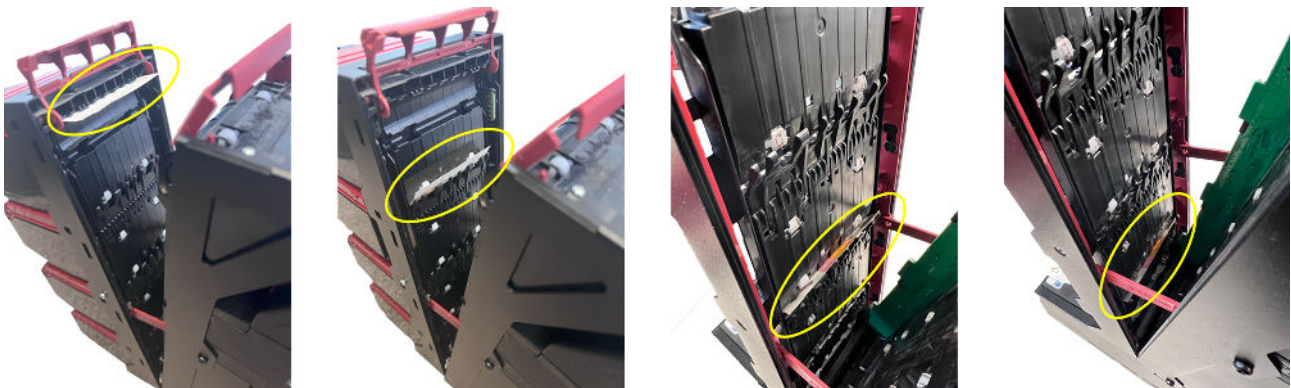

To clear the jam, with the second handle lifted, slowly remove the recycler and open the door and clear the note immediately visible, close the lid and re-assemble the device. When re-assembled run an empty on that recycler then re-float.



WARNING: If you fail to empty the recycler after a jam, further issues could occur.



Guidance on note ownership

During a jam (either accepting or dispensing) one note will be in a pending credit state, the advice below is intended as a guideline, but each integrator can choose to handle the notes as they see fit:

Customer Facing Operations

During accept

A credit won't have been issued by the device if it fails to stack / store so the recommendation would be for the note to be classed as the users.

During dispense

The note won't have been deemed dispensed until it reaches the bezel (or tray), as such the recommendation would be for the note to be classed as the stores.



Important: During a dispense, if a note has fully exited the recycler or dispenser, the note count will already have been decremented. In this case, store staff or technicians should treat that note as **banked**, and remove from the system.

Internal Operations

This section looks at when the counts will be incremented for back office accountancy.

During Float

If the note was fully out of the recycler, the count will be decremented, the cashbox count won't be incremented until the stacked event is thrown (this means its successfully stored the note in the cashbox); so whilst it's between those 2 points store staff or technicians should treat that note as **banked**, and remove from the system.

During Replenish

Some customers treat the replenishment cassette separately to the money contained within the main system (i.e. if an external company is used for refill / collections). In this case the note won't class as stored until it has fully made it's way into the recycler, as such it can be classed as owned by the replenisher.

Testing after an error has been cleared

Once an error has been cleared, ensure the device is tested by inserting bills and paying out notes/tickets where applicable. A recommended test is 10 notes in and 10 notes/tickets out, this will help limit the number of repeat calls for the same issue.

NV4000 Range Approvals

Central Bank Approvals

As part of continual product improvement central banks are regularly visited to gain product certification.

The NV200 Spectral has received independent validation from the [European Central Bank \(ECB\)](#), [Bank of England \(BoE\)](#) and several others.

NV4000 Range Product Compliance

For full details on product compliance and to download certificates, please visit the [NV4000 Range Support Hub](#) page.

EC Declaration of Conformity

The NV4000 is fully compliant with the Declaration of Conformity (CE Marking) and RoHS.

FCC Approval

This equipment has been tested and found to comply with the limits for a Class B digital device, pursuant to part 15 of the FCC Rules. These limits are designed to provide reasonable protection against harmful interference in a residential installation. This equipment generates, uses and can radiate radio frequency energy and, if not installed and used in accordance with the instructions, may cause harmful interference to radio communications. However, there is no guarantee that interference will not occur in a particular installation. If this equipment does cause harmful interference to radio or television reception, which can be determined by turning the equipment off and on, the user is encouraged to try to correct the interference by one or more of the following measures:

- Reorient or relocate the receiving antenna.
- Increase the separation between the equipment and receiver.
- Connect the equipment into an outlet on a circuit different from that to which the receiver is connected.
- Consult the dealer or an experienced radio/TV technician for help.

WEEE



The European Union's directive 2002/96/EC on Waste Electrical and Electronic Equipment (WEEE) was adopted by the European Council and Parliament in 2003 with a view to improving the collection and recycling of Waste Electrical and Electronic Equipment throughout the EU, and to reduce the level of non-recycled waste. The directive was implemented into law by many EU member states during 2005 and 2006. Products and packaging that display the symbol (shown left) indicates that this product must NOT be disposed of with other waste. Instead it is the user's responsibility to dispose of their Waste Electrical and Electronic Equipment by handing it over to an approved re-processor, or by returning it to the original equipment manufacturer for reprocessing.

NV4000 Range Appendix

Contents

- [Cable Drawings](#)
 - [Connector Specifications](#)
 - [Dimensional Drawings](#)
 - [Lock Specifications](#)
 - [Cashbox Handling Advice](#)
 - [File Naming Convention](#)
 - [Lock Inserts](#)
-

Cable Drawings

All parts can be purchased as part of the ITL development kit, details of which can be found on our website.

CN00214 - USB Type A to Type B Cable

DOCUMENT NO. **CN00214** SCALE **1**

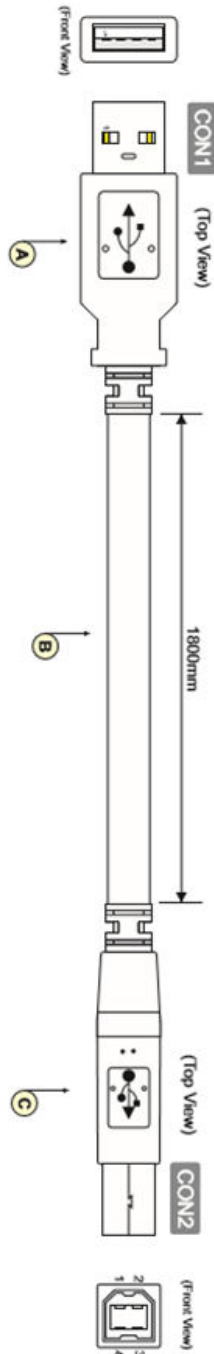

Parts List

Item	QTY	Description	Vendor
A	1	USB Type A Male Connector	-
B	1	USB Shielded High Speed 2.0 Cable 28AWG/1P+28AWG/2	-
C	1	USB Type B Male Connector	-

Comments

Note to Manufacturers
 Certifications are provided for the following:
 ■ RoHS compliance ■ UL 94-V0 rated (connector housing) ■ UL 1581-VW1 rated (all other parts)



30 Amps Programmable
 NOT TO SCALE

USB A to USB B Cable Assembly

DESIGNED BY	DATE	REVISION
C. Cardoza	15/03/2013	1

ISSUE NO.	DATE	BY	FOR
A	15/03/2013	C. Cardoza	Initial Release

All dimensions are in mm ±5mm, unless specified!



CN00370 - SMART Payout Power Only

CN370 **1**

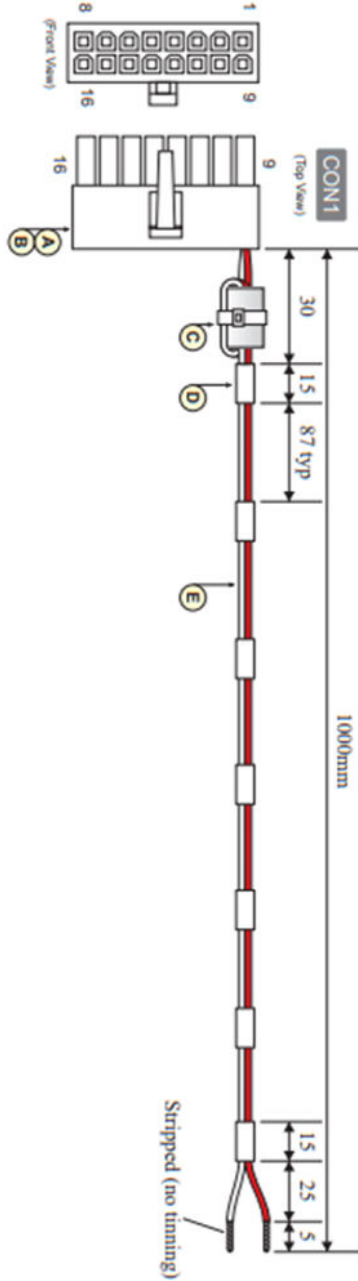

Item	QTY	Description	Vendor
A	1	6740-1160 housing (2x8way 4.2mm pitch with latch, 6A de-rated)	Leotronics
B	4	6744-2000 tin plated, female crimp 10-13-165082160-0 toroidal core Type T	Leotronics
C	1	(16.5x8.2x16mm; single turn; cable tie to secure into place)	Paddiford Electronics;Z:Shan Enterprise
D	10	15mm long, black heat shrink sleeve (spread along the length of the harness with typical separation of 87mm)	-
E	2	Standard 22AWG wire	-

Note:
Pins 8 and 16 are loaded with crimpes but not connected
All other pins are unloaded

REV	DATE	BY	CHKD	APPD	DESCRIPTION
1	16/02/09	A Lunsong			Smart Payout to Host (6A rated connector) - Power only
2					
3					
4					
5					
6					
7					
8					
9					
10					
11					
12					
13					
14					
15					
16					
17					
18					
19					
20					
21					
22					
23					
24					
25					
26					
27					
28					
29					
30					
31					
32					
33					
34					
35					
36					
37					
38					
39					
40					
41					
42					
43					
44					
45					
46					
47					
48					
49					
50					

CN00397 - Payout to Host Cable

CN397
A1

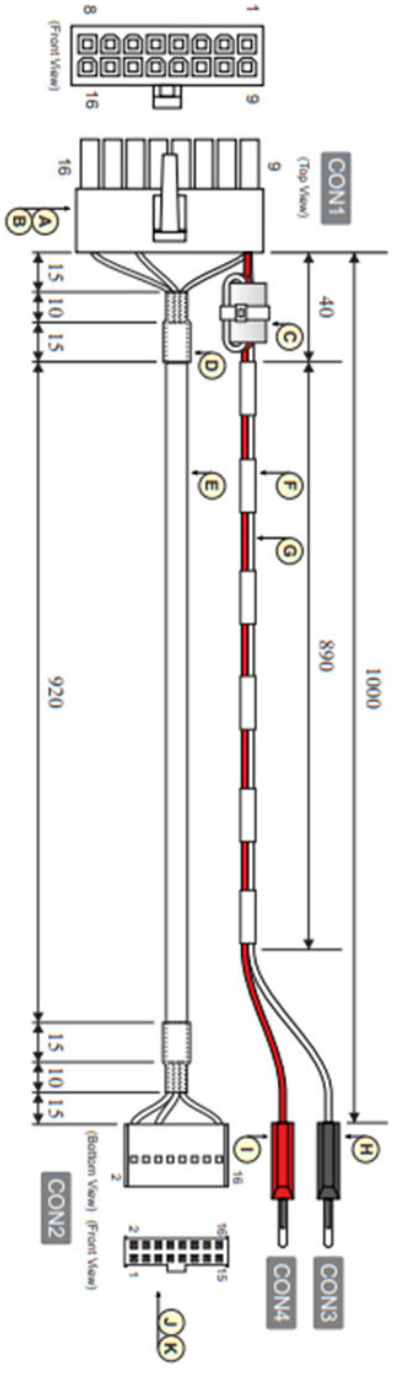

Parts List

Item	QTY	Description	Vendor
A	1	0039012165 housing (2x8way 4.2mm pitch Mini-Fit receptacle)	Molex
B	4	0039000038 tin plated, female crimp 10-13-165082160-0 (KSA T 16 5x8 2x16 toroidal core)	Molex
C	1	(2 turns (1 loop); cable tie to secure in place)	Padelford Electronics/ Z-Shen Enterprise
D	2	25mm long, black heat shrink sleeve	-
E	1	4-core AWM style 2462 24AWG cable 15mm long, black heat shrink sleeve (spread along the length of the harness with typical separation of 82mm)	-
F	10	Standard 22AWG wire	-
G	2	553-0100-01 stackable black 4mm banana plug	Deltron
H	1	553-0500-01 stackable red 4mm banana plug	Deltron
I	1	90142-0016 housing	Molex
J	1	(2x8way 2.54mm pitch with key)	Molex
K	4	9733272 tin plated crimp	Molex

Connectivity

CON1 Pin	CON2 Pin	CON3 Pin	CON4 Pin	Gauge (AWG)	Colour	Comments
1	-	-	-	24	Orange	SSP_TXD_(Vend1)
16	5	-	-	24	Brown	SSP_RXD_(Inhibit1)
9	-	-	1	22	Red	V_IN
1	16	1	-	24/22	Black	GND

Note:
Pin 1 (CON1) has two wires crimped together.
Pin 15 (CON2) is fitted with crimp but not connected.
All other pins are unloaded.
Excess wire in the 4-core cable (item E) is trimmed at either ends. Use 3 core AWM Style 2464 24AWG Cable if available.

Comments
CON1 mates with 6745-2160 straight header (on Smart Payout)
CON2 connects to SSP Hopper Interface Port
CON3 connects to V-(GND) of power supply
CON4 connects to V+(12V) of power supply

All parts must be rated to at least UL94-V0		All connector housings must be rated to UL94-V0		2009 © Copyright of Innovative Technology Ltd		NOT TO SCALE		Smart Payout to Host (6A rated connector) - Power and comms		A Lunsong		DATE: 15/10/09		DRAWN BY:		CHECKED BY:	
All connector housings must be rated to UL94-V0		All connector housings must be rated to UL94-V0		2009 © Copyright of Innovative Technology Ltd		NOT TO SCALE		Smart Payout to Host (6A rated connector) - Power and comms		A Lunsong		DATE: 15/10/09		DRAWN BY:		CHECKED BY:	

CN00398 - Dual eSSP Interface for SMART Hopper & SMART Payout

CN398
1

Parts List		Connectivity		Gauge		Colour		Comments	
Item	QTY	CON1 Pin	CON2 Pin	CON3 Pin	CON4 Pin	CON5 Pin	AWG		
A	1	16	7	-	1	1	24	Orange	SSP TX (Vend1)
B	4	14	8	-	5	5	24	Brown	SSP RX (Ishbit1)
C	1	9	-	-	1	-	22	Red	V IN (12V)
D	10	1	2	1	-	16	24/22	Black	GND
E	2	-	-	-	-	-	-	-	-
F	1	-	-	-	-	-	-	-	-
G	1	-	-	-	-	-	-	-	-
H	2	-	-	-	-	-	-	-	-
I	4	-	-	-	-	-	-	-	-
J	1	-	-	-	-	-	-	-	-
K	8	-	-	-	-	-	-	-	-
L	1	-	-	-	-	-	-	-	-

Notes:
 Pin 14 and 16 (CON1) each has two wires crimped together.
 Pin 1 (CON1) has three wires crimped together. If crimp is unable to hold three wires together please use AWG 26 for the 4-core PVC cable.
 Pin 1 (CON2) is fitted with crimp but not connected.
 Pin 15 (CON5) is fitted with crimp but not connected.
 All other pins are unloaded.
 For the unused wire in the 4-core PVC cable, please trim excess or, if possible, please use a 3-core PVC cable.
 Length for both PVC cable is the same.

Host machine (via CON5) controls both Hopper and Payout through different SSP addresses. Hence, SSP_TX_Vend1 on Payout and SSP_TX on Hopper are both linked to pin 1 (Vend1) on CON5.

Comments:
 CON1 mates with 6745-2160 straight header (on Smart Payout)
 CON2 connects to SSP Hopper Interface Port
 CON3 connects to V- (GND) of power supply
 CON4 connects to V+ (12V) of power supply
 CON5 connects to Host Machine

REV	DATE	BY	CHKD BY	APPV BY	DESCRIPTION
1	15/09/09	A Lumsong			Dual eSSP Interface to both Smart Payout and Hopper assembly

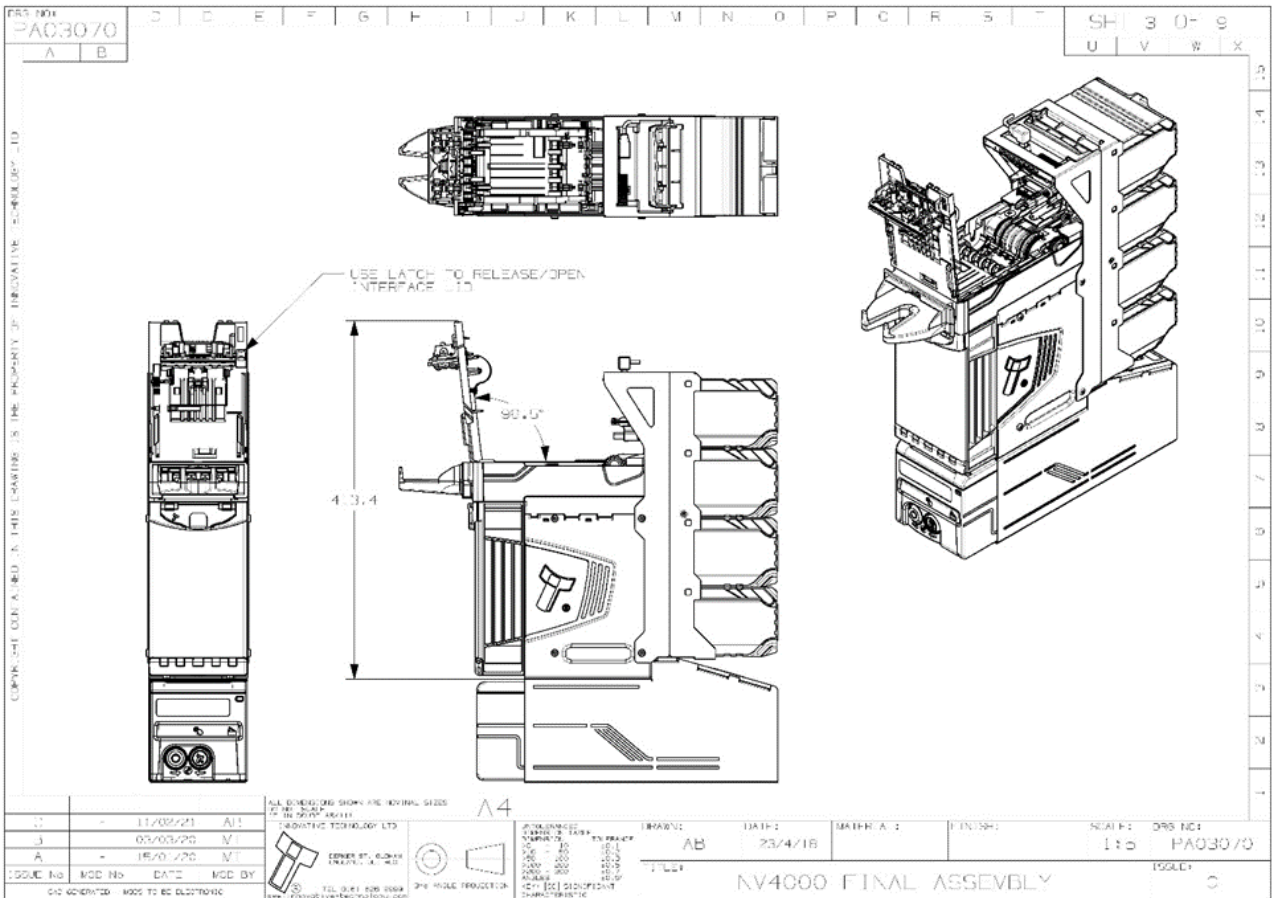
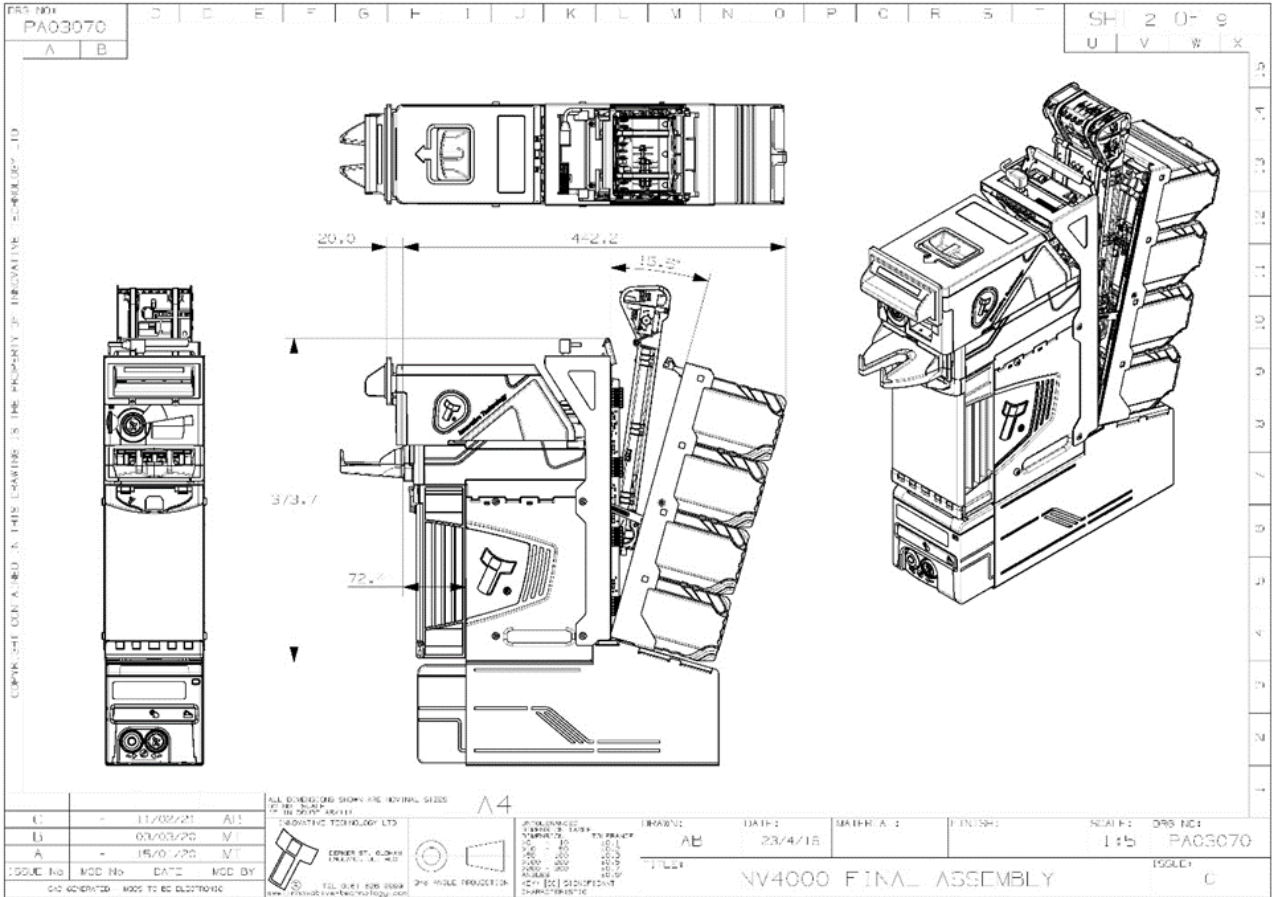

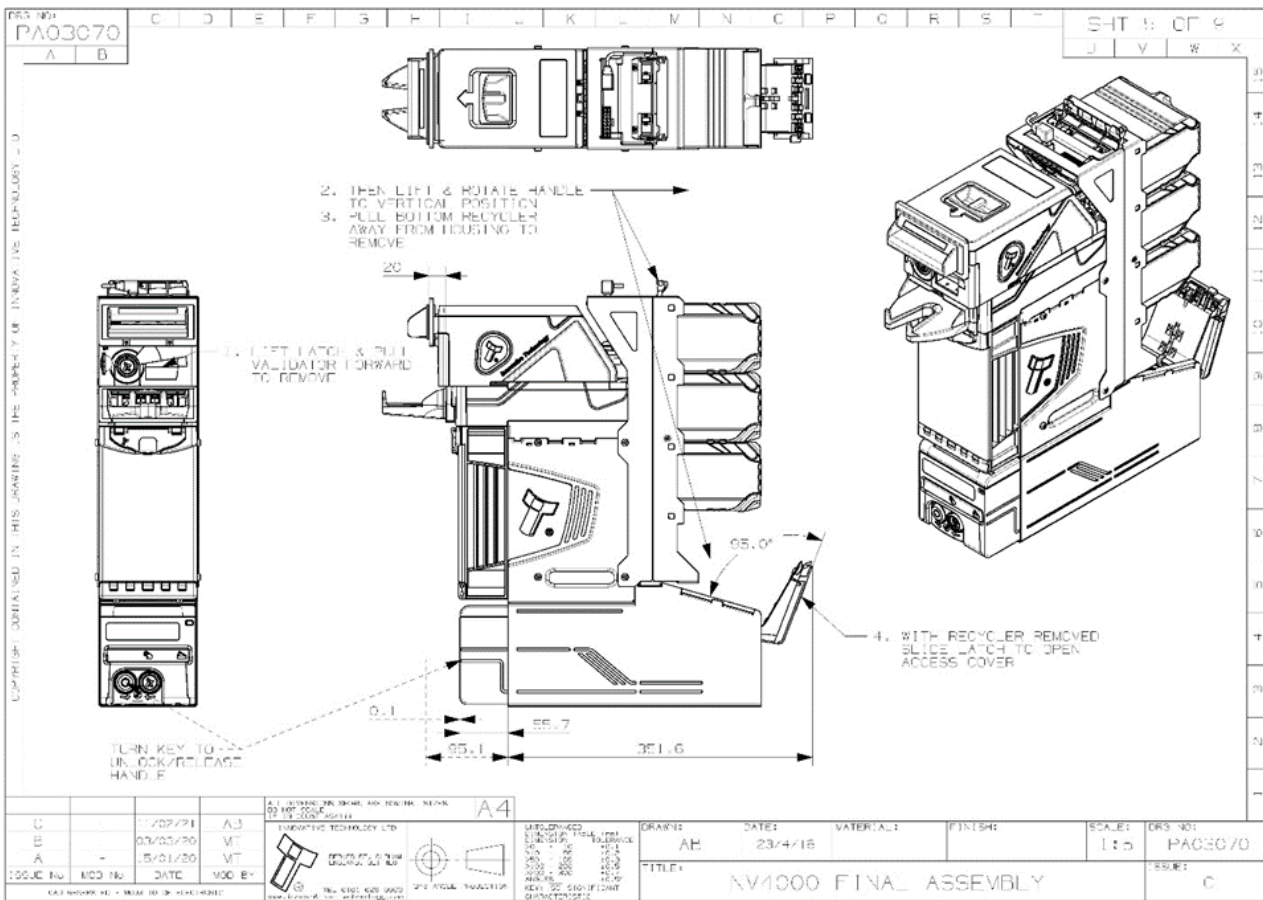
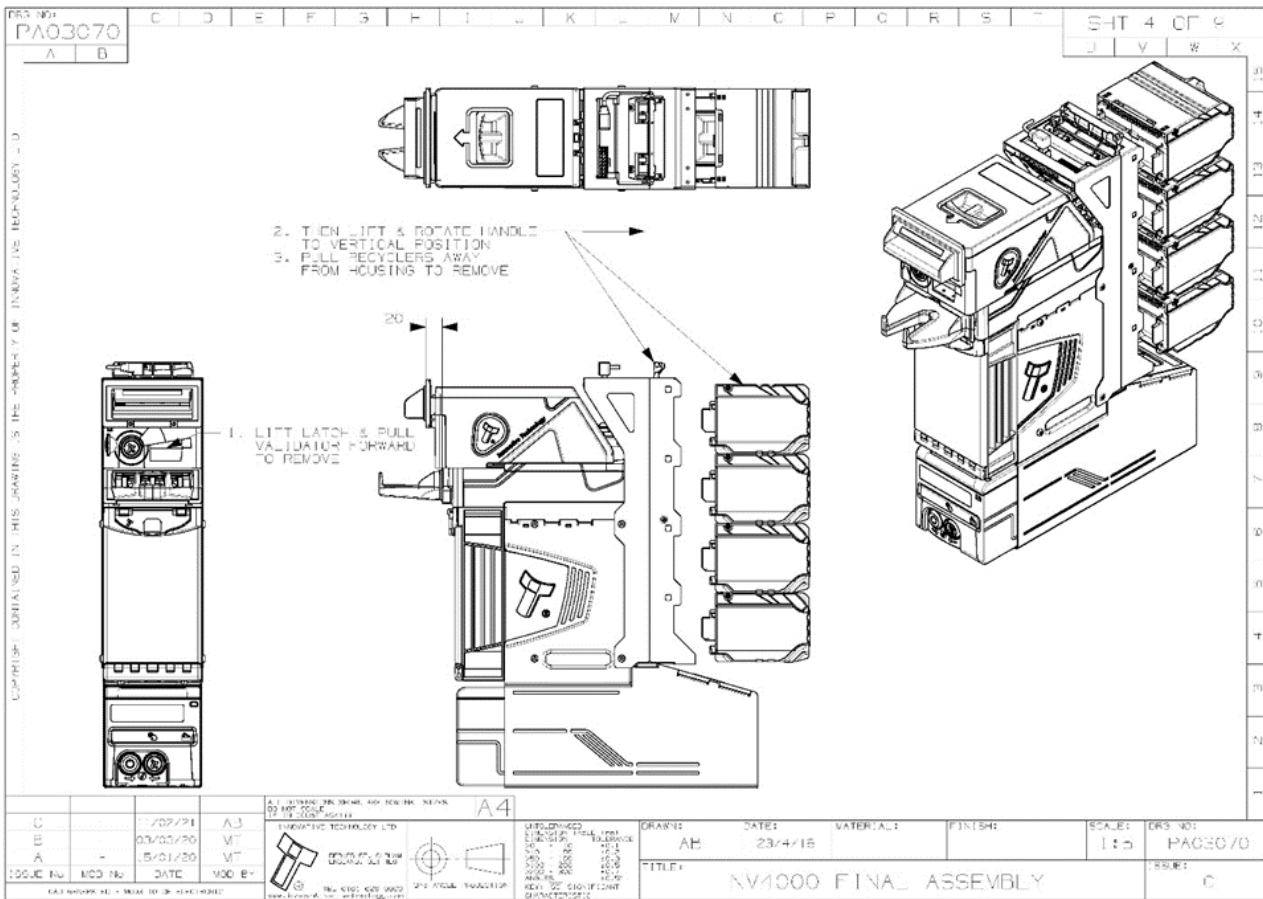

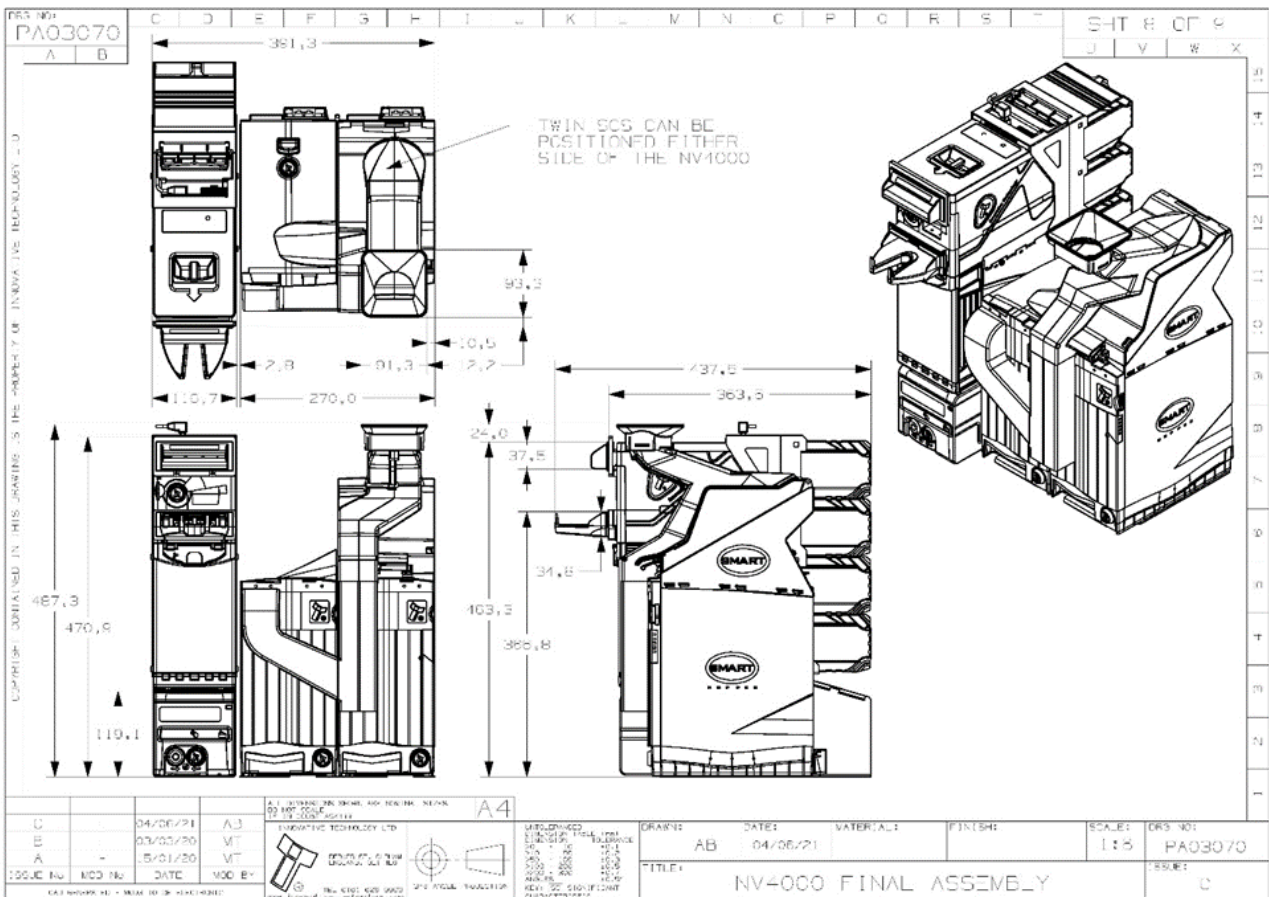
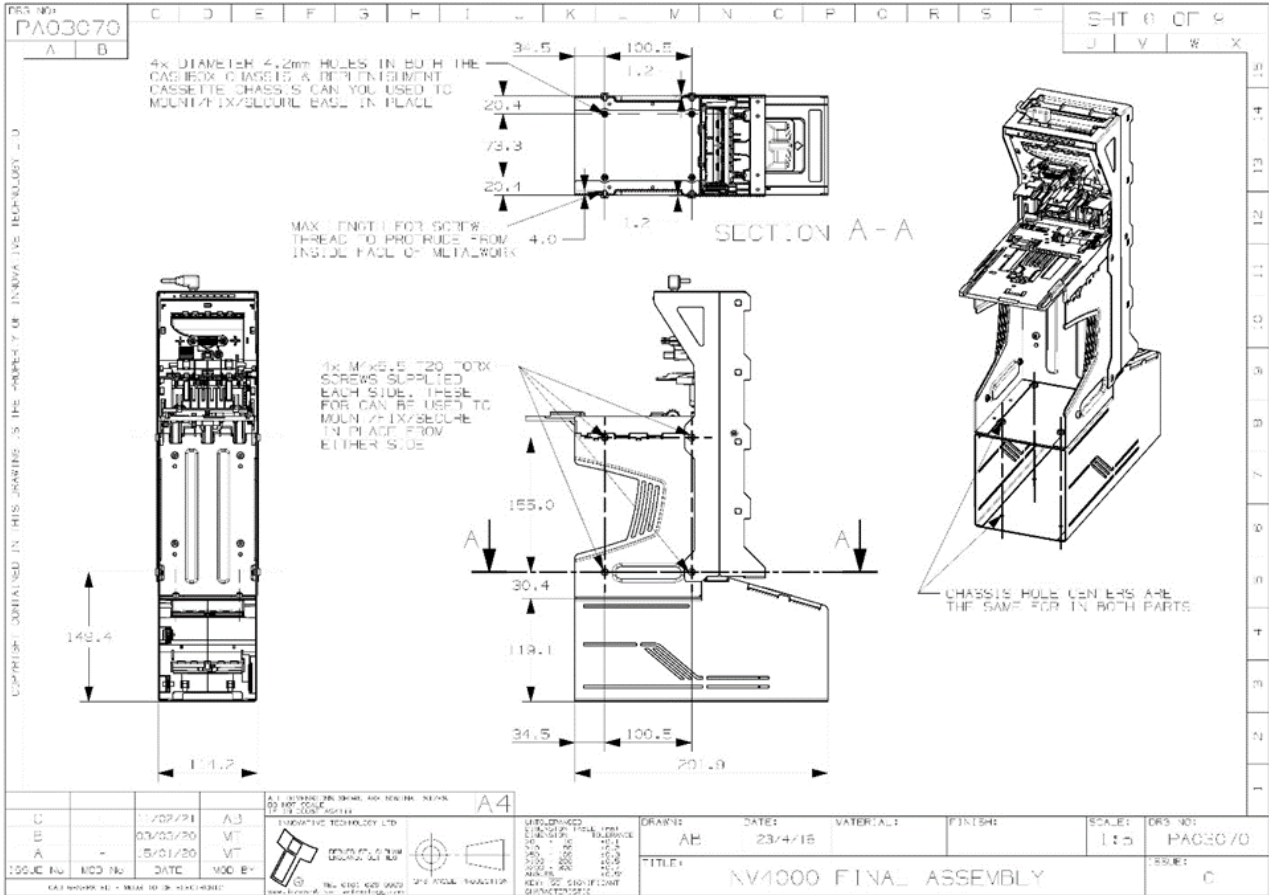

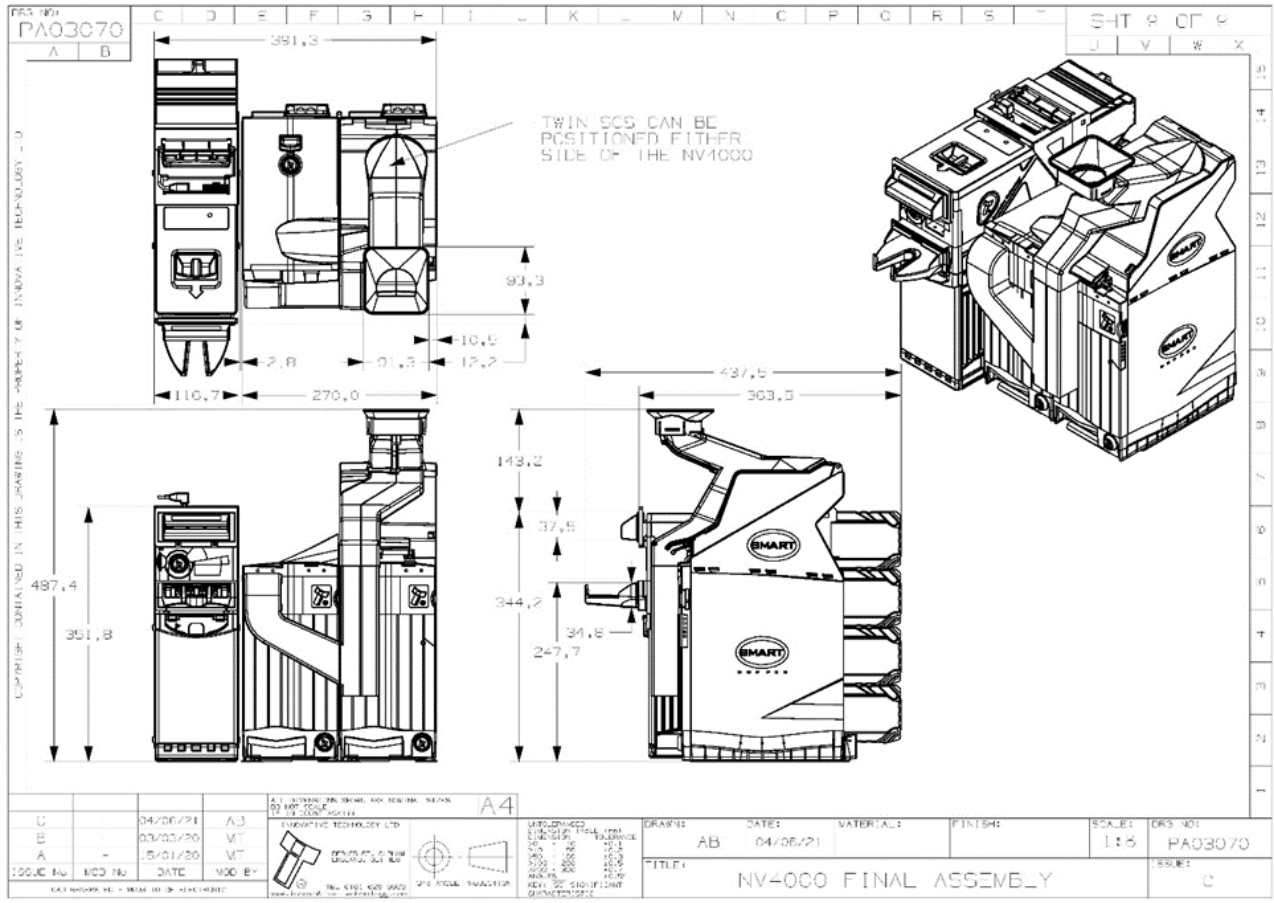

Lock Specifications

PA00650 Camlock

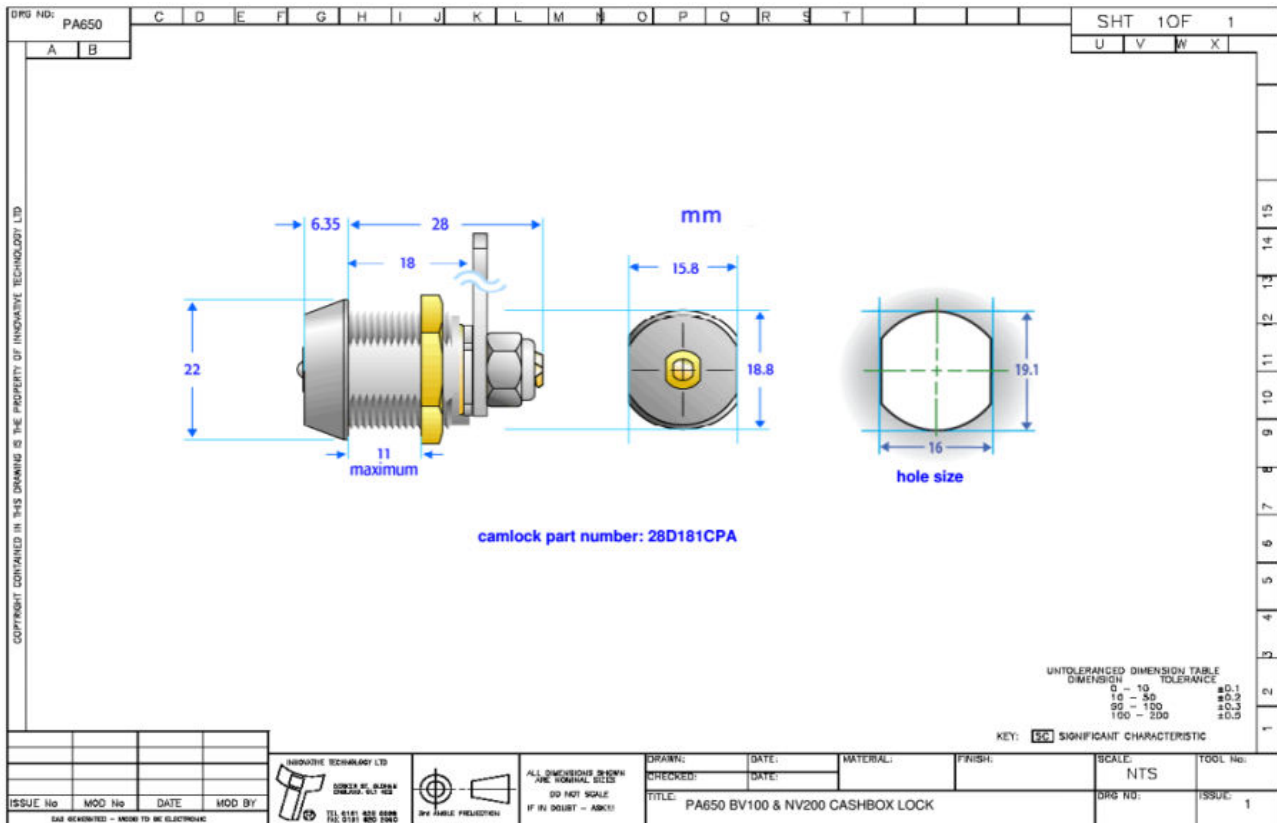

Keyless Locking Cam

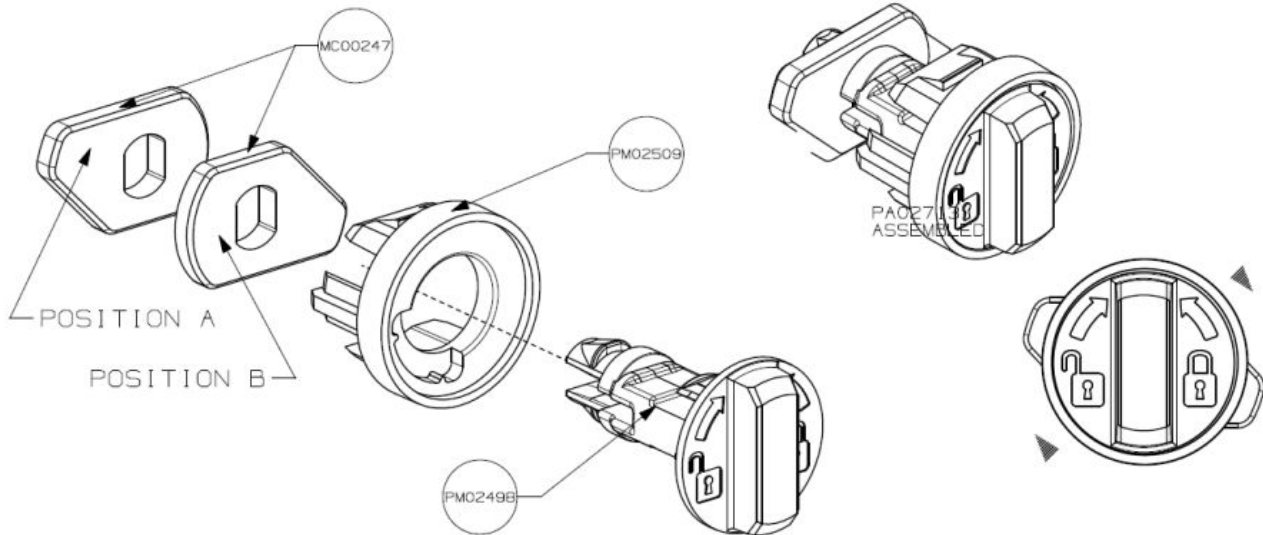

Cashbox Handling Advice

The NV200 Spectral cashbox and TEBS cash bag has been designed to remain intact after an impact of 75cm onto a concrete floor. Dropping the cashbox multiple times can result in physical damage to the cashbox/bag.

File Naming Convention

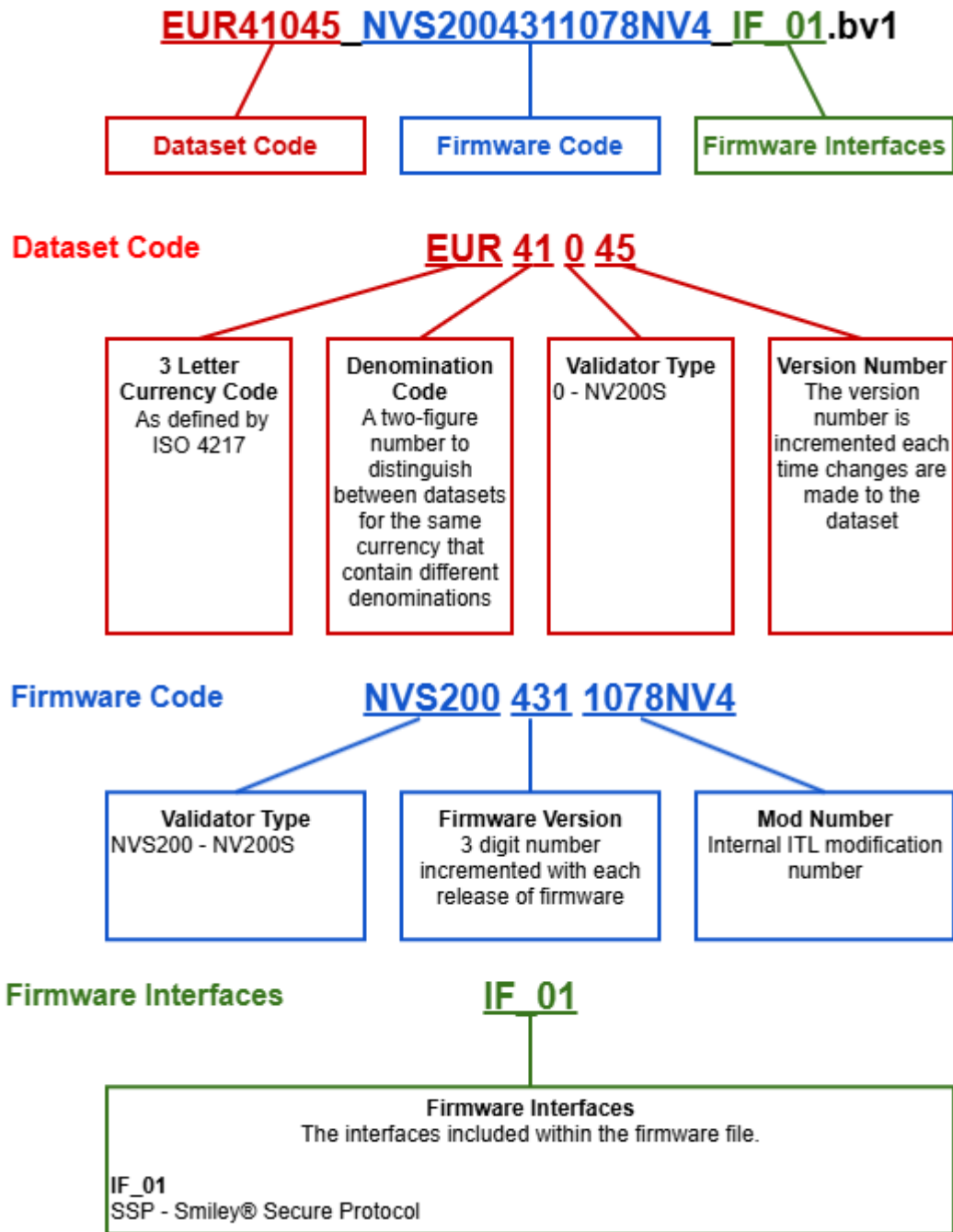

Lock Inserts

The replenishment cassette can be fitted with a range of coloured inserts around the locks as shown in the picture below:



These are fitted in the same way as the lock, refer to [Mechanical Installation](#) for instructions.

NV4000 Range Disclaimer and Safety Information

Contents

- [Disclaimer](#)
- [Product Safety Information](#)

Disclaimer

Innovative Technology:

- Is not responsible for any loss, harm, or damage caused by the installation and use of this product. This does not affect your local statutory rights. If in doubt, contact Innovative Technology for details of any changes.
- Has a policy of continual product improvement. As a result, the products supplied may vary from the specification described here.
- Does not accept liability for any errors or omissions contained within this document. Innovative Technology shall not incur any penalties arising out of the adherence to, interpretation of, or reliance on, this standard.



The contents of this manual set may be subject to change without prior notice.

Product Safety Information



Throughout this user manual, attention should be drawn to key safety points when using or maintaining the product.

These safety points will be highlighted in a box:



This is an example text.

This user manual and the information it contains is only applicable to the model stated on the front cover and must not be used with any other model.

 Danger!	IR and UV Radiation
 	<ul style="list-style-type: none">• Possible skin or eye damage due to presence of IR and UV radiation internally. Disconnect power before servicing• Use PPE measures• Follow safety precautions given in IEC 62471