

Innovative Technology

POWERING TRANSACTIONS AND INTERACTIONS

NV200 Range User Manual

Document Revision - v.1

Exported on 29/04/2026

Change History

Version	Date	Comment
1	23 Dec 2024	Initial Release

 Uncontrolled Document Once Exported.
Please visit the [Support Hub](#) for the latest Information.

Table of Contents

- [NV200 Range Product Introduction](#)
- [NV200 Range Technical Data](#)
- [NV200 Range Mechanical Installation](#)
- [NV200 Range Software Installation and Configuration](#)
- [NV200 Range Protocols and Interfacing](#)
- [NV200 Range Service Guide](#)
- [NV200 Range Product Compliance](#)
- [NV200 Range Appendix](#)
- [NV200 Range Disclaimer and Safety Information](#)

NV200 Range Product Introduction

Contents

- [General Description](#)
 - [Key Features](#)
 - [Typical Applications](#)
 - [Component Overview](#)
 - [Interface Connectors](#)
 - [User Interfaces](#)
 - [Dip Switches on the NV200](#)
 - [Dip Switches on the Payout Module](#)
 - [Bezel Options](#)
 - [Cashbox Options](#)
-

General Description

The NV200 is a high volume, high security banknote validator capable of accepting banknotes up to 85mm wide and 170mm long as well as industry standard bar coded tickets.

With a lockable, removable cashbox that can hold up to 1000 notes the unit is ideal for global high volume applications.

The modular approach enables additional cash handling capabilities to be added with ease. The SMART Payout allows mixed denomination note recycling.

Key Features

- Exceptional note handling
 - Suitable for global applications
 - Add on recycler available
 - Unrivalled mixed denomination note recycler (Recycler Module)
 - Eliminates coin starvation (Recycler Module)
 - Maximises cash efficiency (Recycler Module)
-

Typical Applications

The NV200 validator can be used in a variety of situations where high security and high-volume bank note acceptance and validation are needed. Some typical applications are:

- AWP and SWP applications
 - Self-Serve and Retail
 - Kiosks
 - Casinos
 - Parking and Ticketing
 - Vending
 - Retail environment.
 - POS Systems
-

Component Overview



NV200 Validator



500 Note Cashbox (PA00640 & PA00629)



1000 Note Cashbox (PA00640 & PA00635)



Payout Module (Discontinued)

Interface Connectors

The NV200 validator has two connectors for interfacing and programming; these connectors are easily accessible at the back of the validator.



Power is required regardless of connection type.

Regardless of the connector type being used power is required on pins 15(+V) and 16(0V) of the 16 way connector.

The first connector is a 16-pin Molex 9733272, used to interface the NV200 to the host machine. The pin numbering of the socket is shown below:



When a Payout or Ticket Module is connected a 16-pin Molex 0039012165 connector will replace the 16-pin Molex 9733272, the Pinout is below:

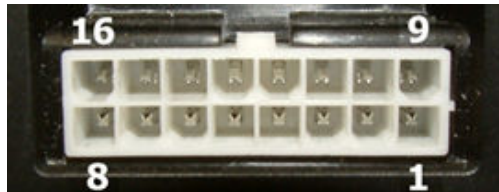

There is also a standard Type 'B' USB socket which can be used for programming the NV200 – a USB 2.0 compliant Type 'A' to 'B' lead can be used to do this.

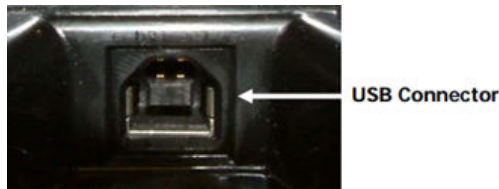

 The USB connection is not recommended for continuous use only for re-programming or troubleshooting.

User Interfaces

Dip Switches on the NV200

The NV200 has a Dual Inline Package (DIP) switch bank that is used to set the various options for the unit. A summary of the switch options are shown below:

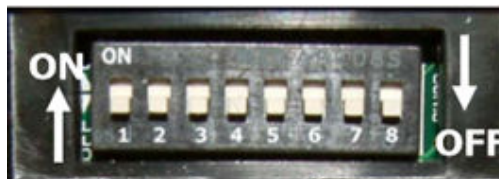

Switch	Option	Switch OFF (↓)	Switch ON (↑)	Default Setting
1	Disable Barcode	Read enabled	Read disabled	OFF
2	Channel 1 Inhibit	Channel enabled	Channel disabled	OFF
3	Channel 2 Inhibit	Channel enabled	Channel disabled	OFF
4	Channel 3 Inhibit	Channel enabled	Channel disabled	OFF

Switch	Option	Switch OFF (↓)	Switch ON (↑)	Default Setting
5	Channel 4 Inhibit	Channel enabled	Channel disabled	OFF
6	Channel 5 Inhibit	Channel enabled	Channel disabled	OFF
7	Channel 6 Inhibit	Channel enabled	Channel disabled	OFF
8	Protocol Select	*Switches between the primary (selected) protocol and SSP (used for Programming). The switch needs to be toggled ON and OFF to alternate between the two. This will cause the unit to reset.		OFF

Dip Switches on the Payout Module

The SMART Payout unit has a Dual Inline Package (DIP) switch bank that is used to set the various options for the unit. A summary of the switch options are below:





Switch	Option	Default Setting
1-6	Not Used	OFF
7	Prevents the NV200 from updating the Payout module	OFF
8	Forces the diverter to close (unit must be powered)	OFF

Bezel Options

ITL Part Number	Description	Image
PA00610	Standard Bezel (85mm)	



ITL Part Number	Description	Image
PA00634	82mm Bezel	
PA00639	Metal Bezel	
PA01038	Self-Aligning Bezel (White)	
PA02053	Self-Aligning Bezel (Black)	

ITL Part Number	Description	Image
PA04224	Coin Resistant Metal Bezel	
PM03081	17mm Bezel Extension	
PM03012	30mm Bezel Extension	

Cashbox Options



Some national currencies differ in thickness and circulation practices. Depending on usage, this can impact cash box capacities by 10-15%. Consult with your ITL representative for more details.

ITL Part Number	Description	Image
PA00640	NV200 Outer Cashbox Chassis	
PA00629	500 Note Inner Cashbox	
PA00635	1000 Note Inner Cashbox	

NV200 Range Technical Data

Contents

- Dimensions
- Weight
 - Standard Unit - No Cashbox
 - Cashbox Options
 - Module Options
- Environmental Requirements
- Power Requirements
 - Supply Voltages
 - Supply Currents
 - Power Supply Guidance
- Interface Logic Levels
 - Opto-Isolated Inputs
- Reliability Data
- Media Requirements
- Central Bank Approval

Dimensions

The dimensions below are for the NV200 with 500 note cashbox. Other cashbox / module options will change the dimensions.

For dimensional drawings of other configurations contact support@innovative-technology.co.uk

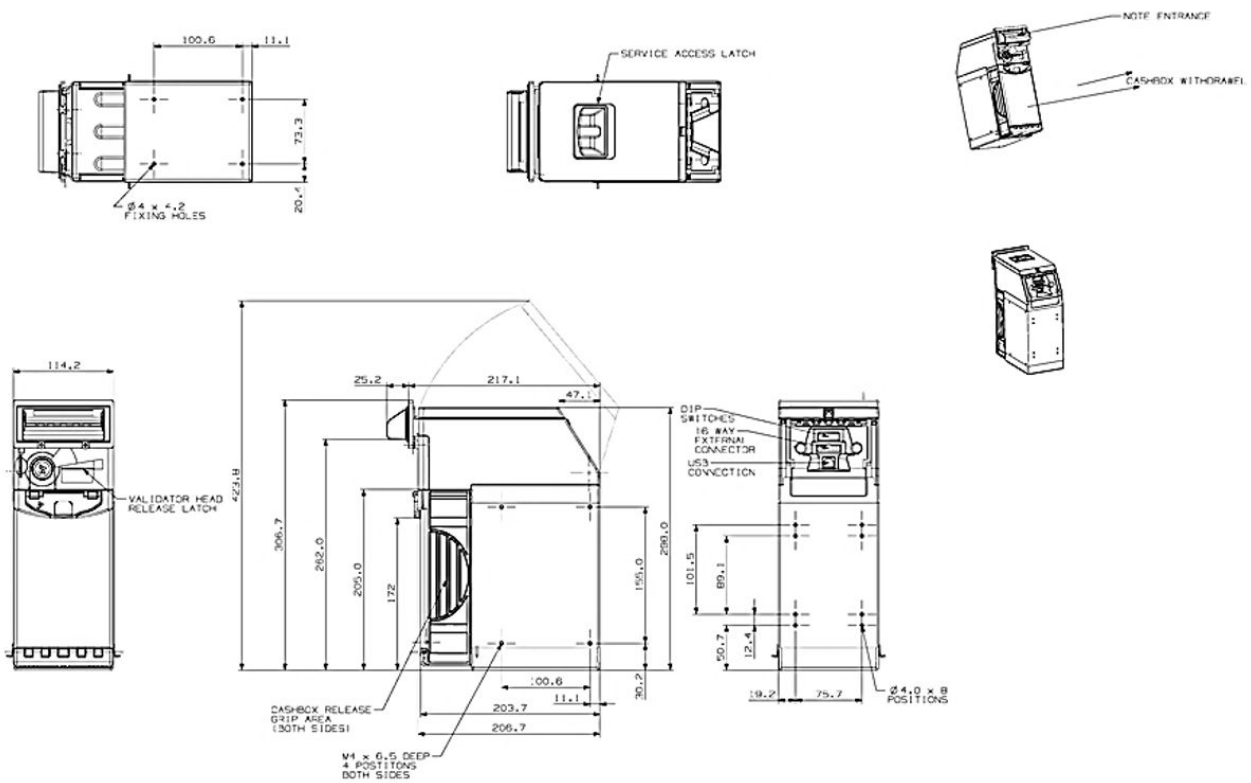

Weight

The tables below show the weights for the individual components of the product.

For example, and NV200 with Standard Bezel and 500 Note Cashbox with Chassis would weigh 3.21Kg (1.20 Kg + 2.01 Kg)

Standard Unit - No Cashbox

Unit	Weight Empty	Weight Full
NV200 – Standard Bezel	1.10 Kg	N/A

Cashbox Options

Unit	Weight Empty	Weight Full
500 Note Cashbox with Chassis	1.76 kg	2.21 kg
1000 Note Cashbox with Chassis	1.94 kg	2.84 kg

Module Options

Unit	Weight Empty	Weight Full
Payout Module	2.54 Kg	2.6 Kg

Environmental Requirements

Environment	Minimum	Maximum	Maximum Change per Hour
Temperature	+3°C / 41°F	+50°C / 122°F	1° per hour
Humidity	5%	95% Non-condensing	2% per hour

Power Requirements

Supply Voltages

Supply Voltage	Minimum	Nominal	Maximum
Supply Voltage (V DC)	+10.8vDC / +21.6vDC	+12vDC / +24vDC*	+13.2vDC / +26.4vDC
Supply Ripple Voltage	0 V	0 V	0.25 V @ 100 Hz



The TEBS cashbox and Ticket module require the unit is run at 24v (±10%).

Supply Currents

The supply current required to run the NV200 will vary during the phases of operation. Below is a table detailing the required current information.

Phase of operation	Current Draw (A)
Standby	400mA
Running	1.5A
Peak	3A

To use the extra modules such as the Payout or Ticket module additional power is required. The table below explains the additional current draw required.

Phase of operation	Additional Current Draw Payout (A)
Standby	-
Running	1.5A
Peak	2A



*Maximum current required to print a solid black ticket

Power Supply Guidance

Please check the power requirements of your host machine and other peripherals to dimension a suitable power environment for your machine setup.

TDK Lambda manufactures suitable power supplies for the NV200. Please see table below for further details.

Power Supply Unit	Specification	RS Stock Code	Farnell Stock Code	Suitable for use with
TDK Lambda SWS50-12	+12vDC / 4.3A	466-5869	1184645	NV200 standalone
TDK Lambda SWS75-12	+12vDC / 6.3A	466-5904	1184648	NV200 with Payout module

Interface Logic Levels

	Logic Low	Logic High
Outputs with 2K2Ω pull-up resistor	+0.6V	Pull-up voltage of host interface
Maximum Current Sink	50mA per Output	
Inputs	0V to +0.5V	+3.7V to +12V

Opto-Isolated Inputs

The NV200 natively supports Opto-isolated communication, the connection requires a reciprocal circuit to be established on the host side.

Reliability Data

paid out that would be classed as 2 cycles.

The difference between MCBF and MCBI is that a failure is classed as an event which will require a service call – e.g. unit is seeing poor acceptance. Whereas an interruption is an event which store/site staff could rectify without a trained engineer present – e.g. clearing a note path jam.

The NV200 is a modular solution and these modules increase the complexity of the system. As such each time, one of these additional modules are attached the current MCBF and MCBI is halved.

MCBF data is available upon request from ITL.

Media Requirements

The NV200 is capable of handling multiple denominations simultaneously, the media that can be accepted includes but is not limited to:

- Polymer notes
- Windowed notes
- Barcoded tickets

The minimum and maximum dimension for media IN is as follows:

	Min	Max
Length:	110mm	170mm
Width:	56mm	85mm

When using the optional Payout module the media dimensions are as follows:

	Min	Max
Length:	110mm	170mm
Width:	56mm	82mm

Central Bank Approval

As part of continual product improvement, central banks are regularly visited to gain product certification. This includes but is not limited to the following ECB, BoE & FED.

NV200 Range Mechanical Installation

Contents

- [Compatibility](#)
 - [Hardware Compatibility](#)
 - [Software Compatibility](#)
 - [Bezel Mounting](#)
 - [Bezel Fitting](#)
 - [Cashbox Removal](#)
 - [Standard Cashbox Removal](#)
 - [Lock Mounting](#)
 - [Lock Fitting NV200](#)
 - [Lock Fitting - Standard Cashbox](#)
 - [Lock Specification](#)
 - [Lock Cam](#)
 - [Machine Mounting](#)
 - [Machine Mounting - Standard Cashbox](#)
 - [Things to consider](#)
 - [Earth Bonding](#)
 - [Screw Specification](#)
-

Compatibility

Hardware Compatibility

Machine Mounting

The NV200 is not retrofittable in place of any older Innovative Technology validator however it's footprint is comparable to other high-end casino validators, some re-work may still be required to use the NV200 in place of a different validator.

By design the NV200 family is pin to pin across the range. If integrating different modules, a change in the harnessing may be required.

Power Supply

It is vital that the NV200 is connected to a power supply capable of meeting the current requirements as an under powered PSU can cause events such as note rejects or missing credits. If the NV200 is used as a fitting replacement for an older product its recommended to test the power supply ensuring it meets the requirements of the NV200; please bear in mind the aging of the capacitors in the power supply could affect its ability to supply peak current loads.

Software Compatibility

Interface Protocols

When using the NV200 as a fitting replacement for an older model or product some events such as credits may be given at a different time, due to modified firmware routines. This may cause missing events such as credits in certain host machines where timeouts are tightly defined for the older model or product. Please contact the machine manufacturer for full compatibility.

Re-programming

For re-programming the NV200 always use the latest version of Validator Manager which is available for download on our website. Older versions may not fully support the NV200.

Bezel Mounting

Bezel Fitting

The bezel should be secured to the validator head using screws if the NV200 is being installed and transported inside a host machine.

The length of the bezel fixing M3 screws must be no more than 12 mm in length.

The bezel is designed to be removed and refitted easily. To remove or refit the bezel, access to the note path is required – the top cover must be open fully to allow access to the bezel mounting area.

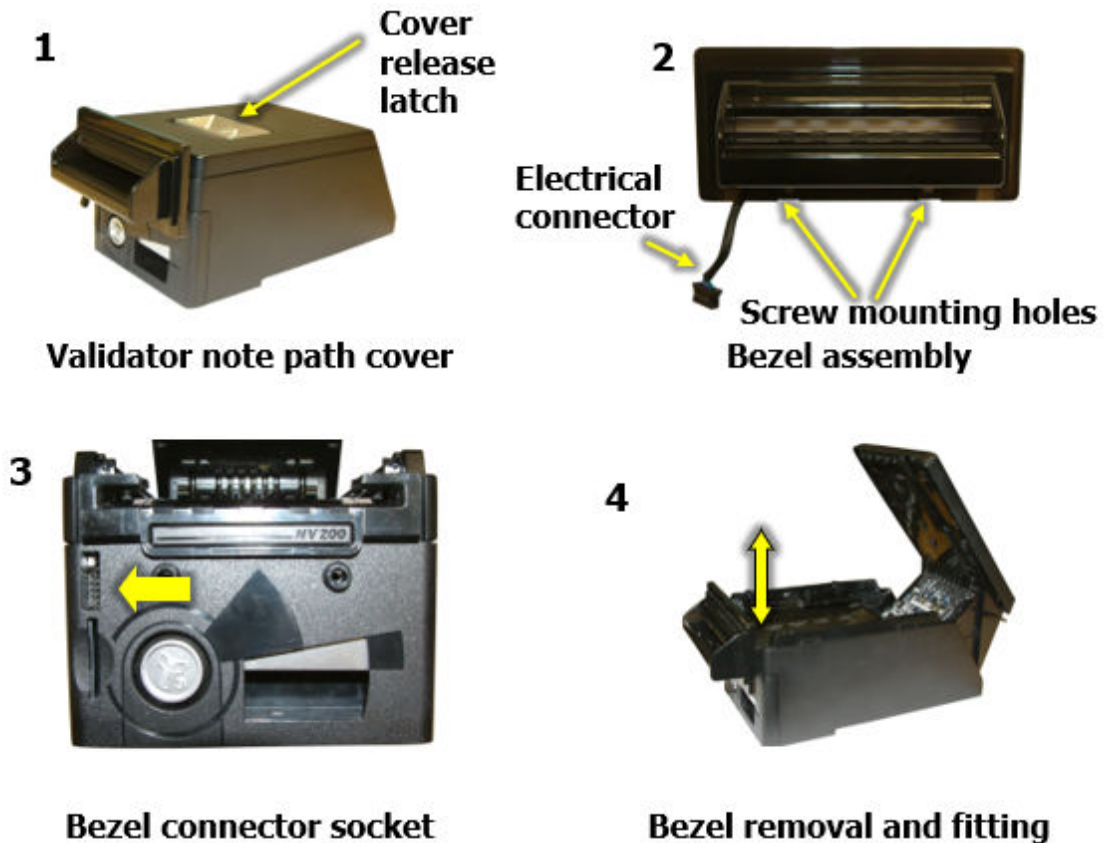

Fitting the bezel: Lift the upper cover by pulling the latch forward as shown in picture 1.

Connect the cable from the bezel assembly (as shown in picture 2) to the socket located on the front of the validator head (as shown in picture 3) and slide the assembly down into place and close the note path upper cover (as shown in picture 4). If required, the bezel can be secured in place with two M3 screws - these are fitted in the two holes at the bottom of the bezel.

 When fitting the bezel please ensure the NV200 is removed from the cashbox to prevent any issues with fitting.

Cashbox Removal

Standard Cashbox Removal

To remove the cashbox, pull the handle away from the unit, this will unlatch the cashbox before allowing them to slide out.

 The NV200 may have to be unlocked before removing the cashbox.

500n Cashbox:



1000n Cashbox:



When the cashbox has been removed to access the money, turn it upside down and open the flap as shown in the picture to the right.

 There may be a further CAM lock at the bottom of the cashbox.



Lock Mounting

Lock Fitting NV200

The Lock can be fitted to the front of the NV200 replacing the silver front plate (shown to the right) which ships by default.



Before the lock can be installed, remove the NV200 from the cashbox chassis. Lift the latch, slide the head forward and lift the head away from the chassis.

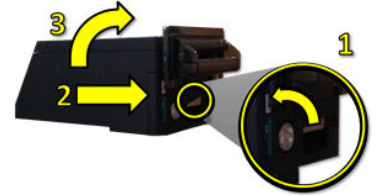

There are 2 x T8 screws located on the underside of the NV200, remove those and lift away the plastic insert.

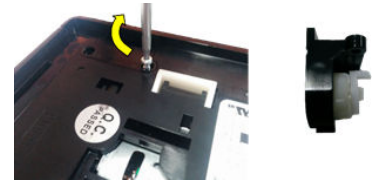

Press the plastic clip together and remove the locking cam.



To remove the plastic insert, from the lock mount, press the two clips on the side together and push through. Insert the cam lock in its place.



Re-attach the locking cam onto the barrel of the lock and tighten.



To fit the assembled lock into the unit place the bottom in first then push the top into position.



Turn the unit upside down and screw in the 2 x T8 screws previously removed.

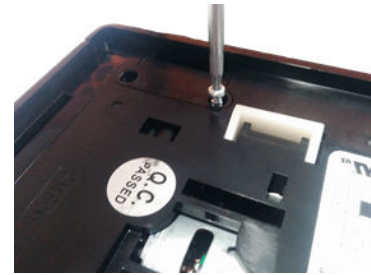

Lock Fitting - Standard Cashbox

The standard NV200 cashbox can be fitted with 2 locks for security. These are located on the bottom of the cashbox on the hinged door.



Similarly, to fitting a lock on the front of the NV200 remove the locking cam and blanking plate which is there by default and replace with the desired lock.



With the lock in place add the washer and the locking cam.

ⓘ Ensure when the keylock is turned the locking cam is inserted in the same position it was previously removed otherwise it can cause interference.



Lock Specification

Locks for the NV200 are available from Innovative Technology Ltd.

ITL Part Number	Description
PA00650	Standard Lock for NV200

ⓘ There are various lock manufacturers and distributors.

Lock Cam

The following Lock Cam needs to be ordered from Innovative Technology Ltd. additionally to the lock for full locking capability.

ITL Part Number	Description
PM00614	NV200 Lock Cam
MC00247	Cashbox Lock Cam

Machine Mounting

Machine Mounting - Standard Cashbox

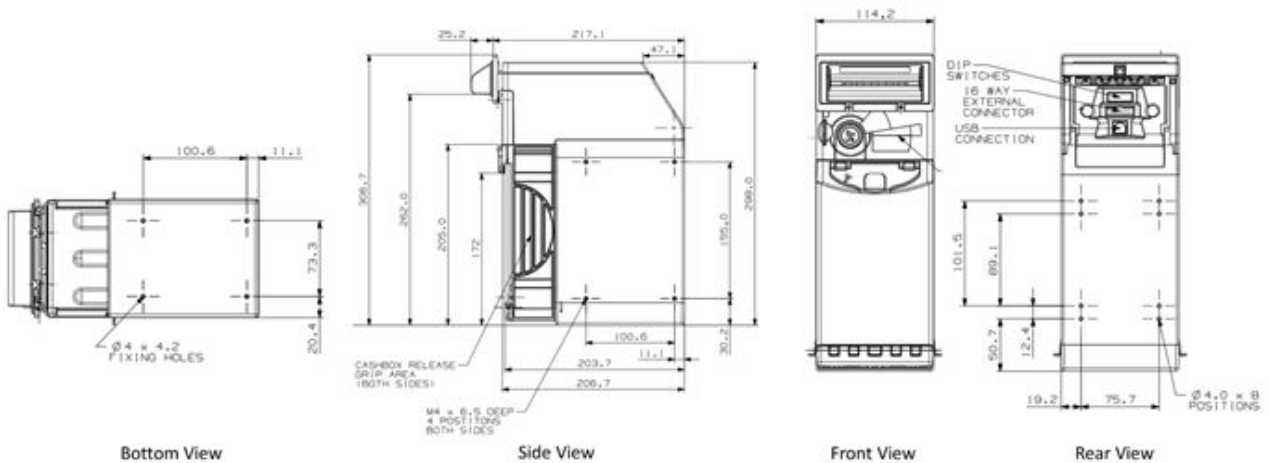

Things to consider

When mounting an NV200 there are several things to consider including:

- Accessibility – ensure it is possible to reach all connectors and switches if required.
- Cable management – to ensure no connectors are damaged/removed from everyday use.

Earth Bonding

It is very important that the product is properly bonded to earth, using one of the earth tabs. Earthing on the standard chassis can be affixed to any of the screw mounting points at the side of the unit.



Lack of proper bonding can cause communication issues and other failures. The resistance between the chassis and Earth should be less than 0.7Ω.

Screw Specification

The scope of delivery does not include screws for machine mounting. See table below for screw specification reference.

Location	Thread Type	Screw Length
NV200 Bezel	M3	12mm
NV200 Cashbox	M4	6mm

NV200 Range Software Installation and Configuration

Contents

- [Introduction](#)
- [Software Downloads](#)
 - [Drivers](#)
- [Dataset/Firmware Programming](#)
 - [Validator Manager](#)
 - [SD Card](#)
 - [Remote Updates](#)

Introduction

The NV200 leaves the factory programmed with the latest dataset and firmware files. However, it is important to ensure the device is kept updated throughout its operational life. This section provides a brief overview of the various update procedures with the NV200. For detailed instructions please refer to the relevant manual package supplied with the software.

 The extra modules are updated through the NV200, as such once the programming has been completed on the validator it will begin to update the connected modules e.g. payout.

Software Downloads

All software from Innovative Technology Ltd is free of charge and can be downloaded from the [Support Hub](#) once registered. To create an account complete the 'create an account' form.

As of June 2016 the ASIC chip used in the NV200 was made obsolete by the manufacturer. As such a new board revision with a different processor was released. This resulted in a different hardware revision and firmware version, please see below:

1. The revision has been increased to Revision 30 (from 25).
2. The NV200 with ST chipset will have its own 'validator type' referenced in the dataset name (see below):

Previous NV200 - GBP58**6**20

NV200 with ST chipset - GBP58**G**20



Ensure the correct version of firmware is being used for the product.

Drivers

The ITL drivers suite allow any ITL validator to be connected to a Windows device. If connecting via an IF17 these steps shouldn't be required as the drivers are signed so Microsoft should install them automatically. If this isn't the case or your computer is disconnected from the network, there is a standalone package included within the driver downloads.

Dataset/Firmware Programming

Validator Manager

General Description

Validator Manager is a utility which allows the user to reprogram any of ITL's currently supported devices.

- Admin rights are required during installation. The validator must be in SSP for the Validator Manager to detect the device.

System Requirements

- Windows 8.1 or above
- .Net Framework 4.5 or above
- 2015 C++ Redistributable
- 256mb ram
- 50mb hard disk free
- ITL Drivers
- Connected validator with active com port
- Validator must be in SSP

- We have seen instances where one of the dll's (itdata1.dll) used in Validator Manager are classed as a Trojan, this is a false positive and if this happens you will need to add a rule for your antivirus to allow the file to run.

Hardware Setup

There are many ways to connect the NV200 to the computer. Below is a typical example:

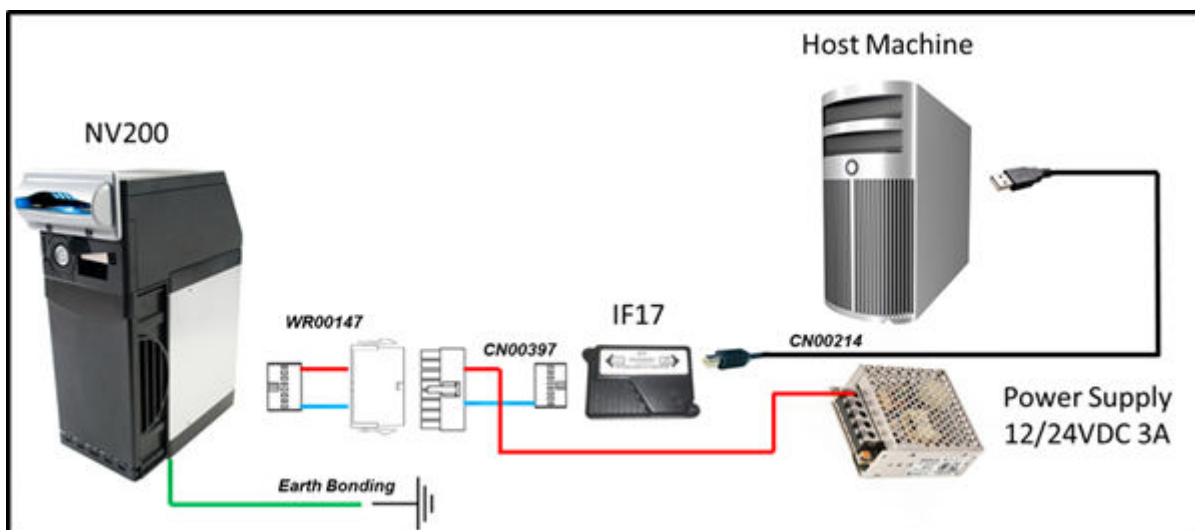

Switching to Programming Mode (SSP)

Before programming via the Validator Manager, the NV200 needs to be switched to its programming mode (SSP interface), see [Switching to Programming Mode](#).

Programming the Device

Once the unit is switched to SSP, open Validator Manager and click detect devices. This will scan all active com ports for a unit, if your NV200 fails to connect please ensure the correct drivers are installed and the unit is in SSP.

By selecting the Program tab, the NV200 can be programmed. To begin the upload, click open file, browse to the file location (usually Downloads) and click OK.

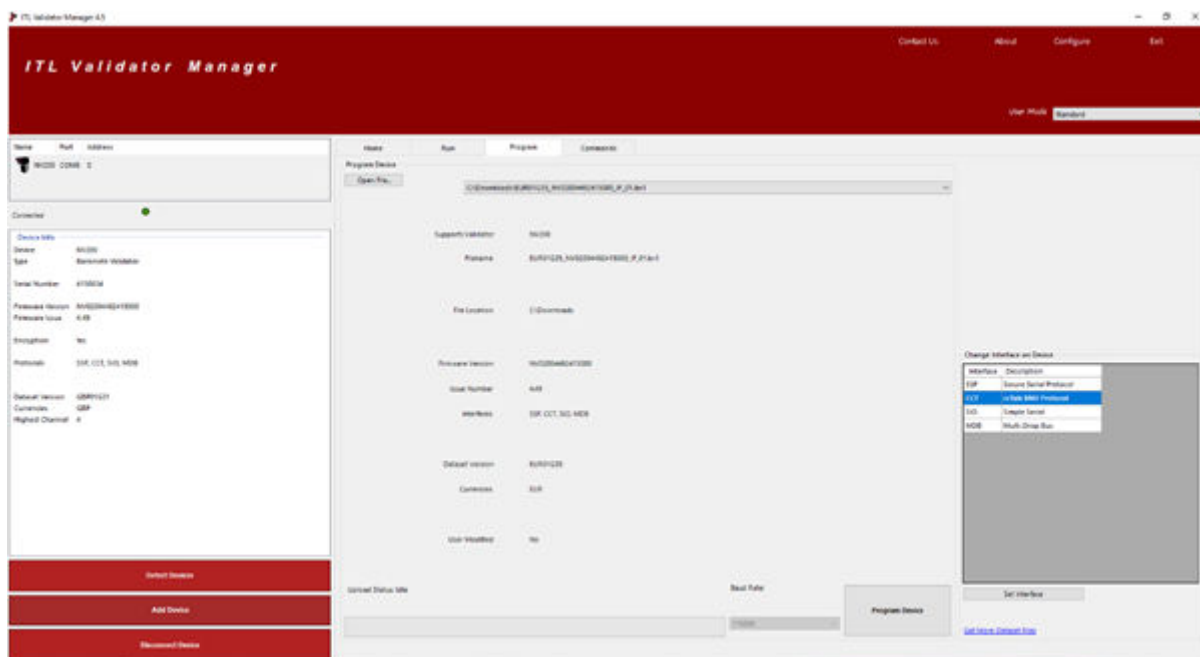

Once the file has been selected its information will be populated and the Program device tab will become active. Select 'Program Device', the unit's bezel will begin to flash signalling the update has begun.

When completed the unit will restart and a pop up box will appear saying Device Programming Complete.

SD Card

General Description

The NV200 can also be reprogrammed through the SD slot on the front of the unit; to program a card to update the unit NV Card Utilities must be used. NV Card Utilities allows the user to create update cards for the NV200 family of products.

System Requirements

- Windows 8.1 or above
- .Net Framework 4.5 or above
- 2015 C++ Redistributable
- 256mb ram
- 50mb hard disk free
- ITL Drivers
- Connected DA3 with active com port

Re-programming via SD Card

A full guide of how to create an update card can be found in the software manual.

Once the appropriate card has been generated insert it into the card slot on the NV200.

The bezel will begin to flash blue and pink, once the download is complete the bezel will go solid green.

Remove the SD card, the NV200 will begin to update any attached device (Payout).

If a device is attached its LED Status Indicator will flash indicating the unit is being updated.

SMART Update

Smart update is a utility which bundles up a regions dataset into one file which can be placed on an SD card, this can then be inserted into the SD card slot at the front of the NV200 and it will update with the latest version of the dataset currently loaded onto the unit. No settings will be altered during the update only the dataset and firmware.

Remote Updates

Smart update is a utility which bundles up a regions dataset into one file which can be placed on an SD card, this can then be inserted into the SD card slot at the front of the NV200 and it will update with the latest version of the dataset currently loaded onto the unit. No settings will be altered during the update only the dataset and firmware.

NV200 Range Protocols and Interfacing

Contents

- [Introduction](#)
- [SSP and eSSP](#)
- [ccTalk®](#)
- [SIO and SI2](#)
- [MDB](#)
- [Pulse](#)

Introduction

The NV200 supports standard industry protocols. Interfaces that are not listed may be available upon request. For any queries regarding interfaces that are not listed please contact support@innovative-technology.com.

SSP and eSSP

General Description

Smiley® Secure Protocol (SSP) is a field proven secure interface specifically designed by Innovative Technology Ltd. to address the problems by cash handling systems in gaming machines. Problems such as acceptor swapping, re-programming and line tapping are all addressed. This interface is recommended for all new designs. Innovative Technology Ltd. provides full SDK packages upon request including Interface Specification, Implementation Guide as well as source code examples.



Pin Assignments

Whilst the optional modules for the NV200 use a clipping 16-pin connector in place of the standard NV200 connector, the pin outs are largely the same, please see below:





NV200 Connector

Pin	Name	Type	Description
1	Tx	Output	Serial Data Out (Tx)
2	Tx Opto Emitter	Output	Opto isolated Tx Emitter

Pin	Name	Type	Description
3	Rx Opto +	Input	Opto Rx+
4	Rx Opto -	Input	Opto Rx -
5	Rx	Input	Serial Data In (Rx)
6	Tx RS232	Output	RS232 TX
7	Tx RS232	Input	RS232 Rx
8	 Not Used		
9	Tx Opto Collector	Output	Opto Isolated Tx Collector
10 - 14	 Not Used		
15	+V In	Power	+12/24V DC Supply
16	0V	Power	0V Supply (GND)

SMART Payout Connector

Pin	Name	Type	Description
1	0V	Power	0V Supply (GND)
2 - 3	 Not Used		
4	Rx Opto -	Input	Opto Rx -
5	 Not Used		
6	Rx Opto +	Input	Opto Rx +
7	 Not Used		
8	Tx Opto Emitter	Output	Opto Isolated Tx Emitter
9	+V In	Power	+12/24V DC Supply

Pin	Name	Type	Description
10	⚠ Not Used		
11	Rx RS232	Input	RS232 Rx
12	⚠ Not Used		
13	Tx Opto Collector	Output	Opto Isolated Tx Collector
14	Rx	Input	Serial Data In (Rx)
15	Tx RS232	Output	RS232 Tx
16	Tx	Output	Serial Data Out (Tx)

Setup Samples

NV200

The drawing below highlights how to connect the NV200 to an SSP host machine using available cables and interfaces from Innovative Technology Ltd.

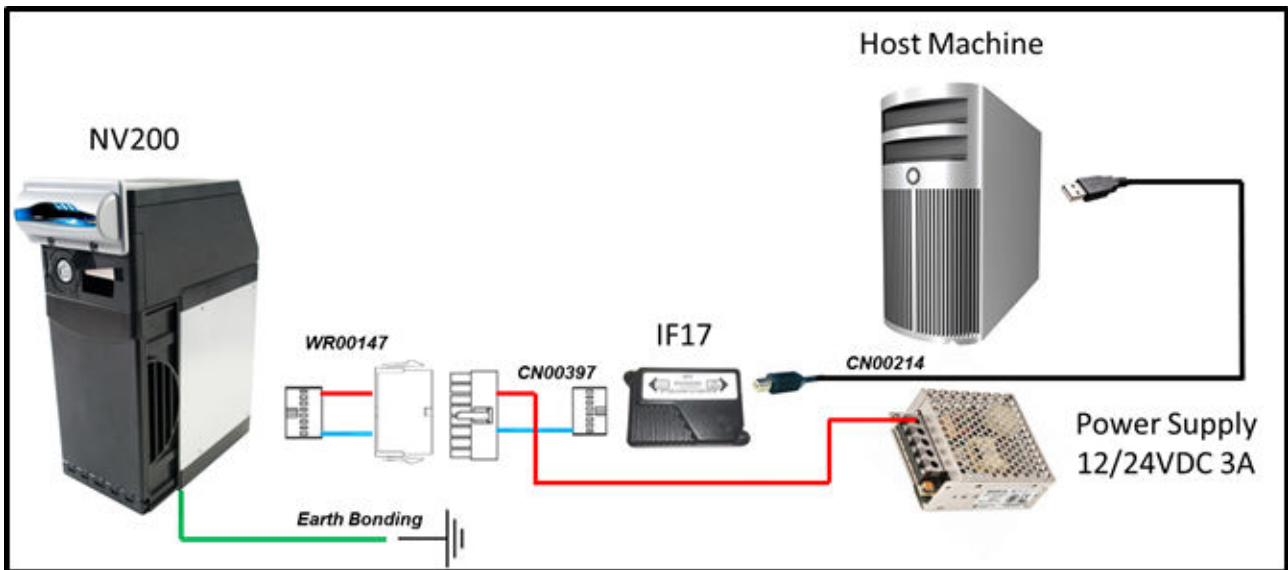

Type	ITL Part Number	Description
Cable	CN00397	SMART Payout to Host Cable
Cable	WR00147	SMART Payout to NV200 Adaptor
Cable	CN00214	USB A to B cable assembly

Type	ITL Part Number	Description
IF17	IF17	IF17 Interface Converter

SMART Payout (Discontinued)

The drawing below highlights how to connect the SPO to an SSP host machine using available cables and interfaces from Innovative Technology Ltd.

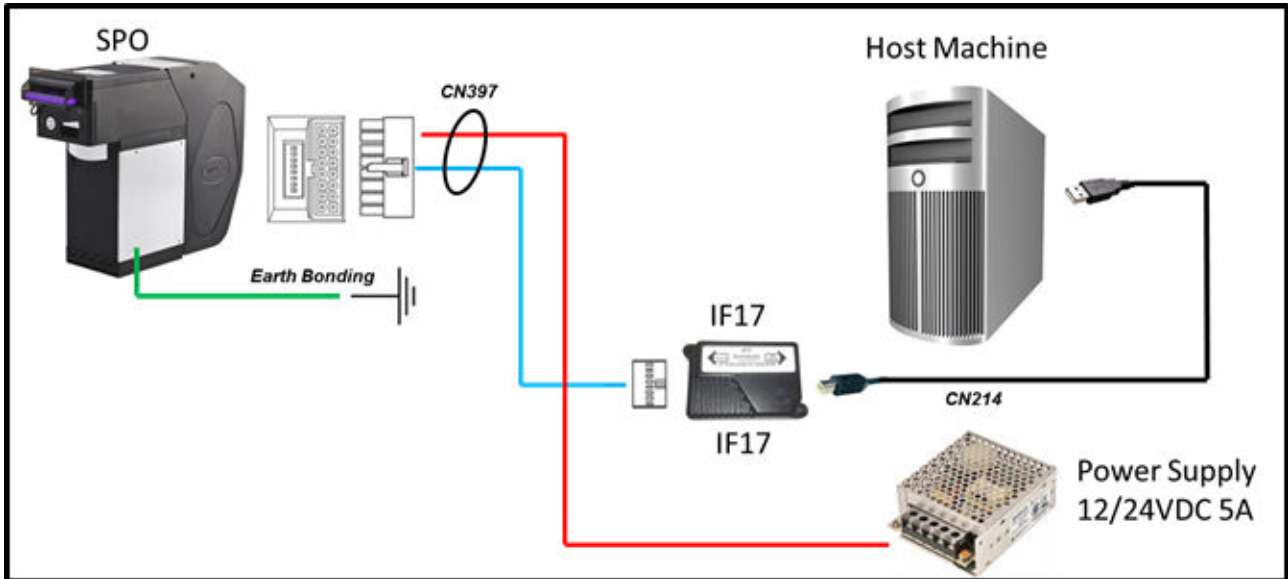

Type	ITL Part Number	Description
Cable	CN00397	SMART Payout to Host Cable
Cable	CN00214	USB A to B cable assembly
IF17	IF17	IF17 Interface Converter

ccTalk®

General Description

ccTalk® is a serial communications protocol designed to allow 3-wire interfacing between a host and cash handling peripherals.

From the NV200 family only the NV200 with standard cashbox and Payout module are capable of communicating via ccTalk.

Pin Assignments

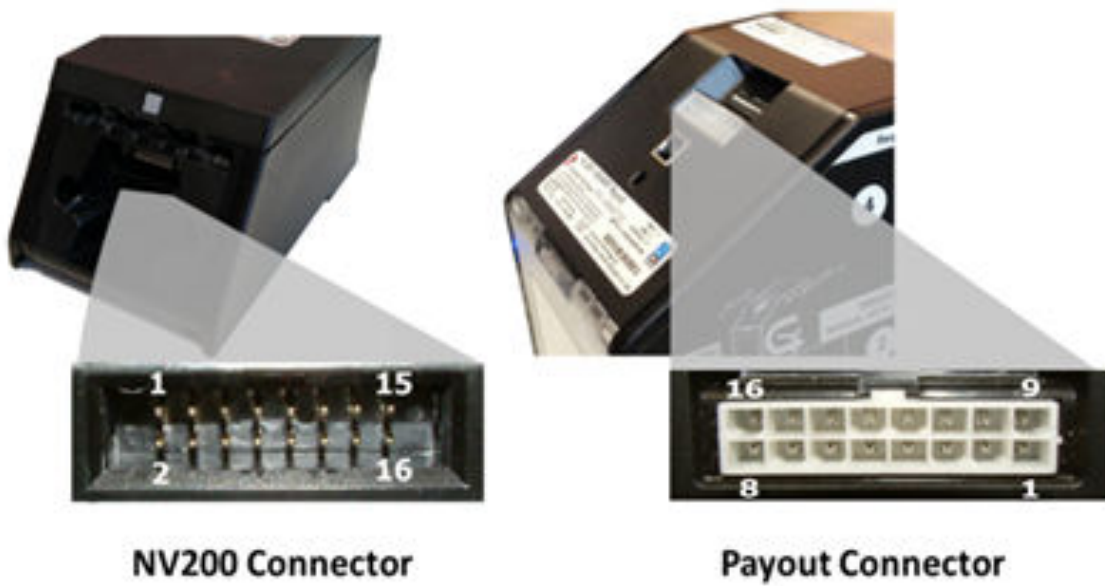

NV200 Connector

Payout Connector

NV200 Connector

The connectors for the NV200 can be seen below:

Pin	Name	Type	Description
1	TTL Transmit (Tx)	Output	Serial Data (optionally link to Pin 5*)
2 - 4	⚠ Not Used		
5	TTL Receive (Rx)	Input	Serial Data (optionally link to Pin 1*)
6 - 14	⚠ Not Used		
15	+V In	Power	+12/24V DC Supply
16	0V	Power	0V Supply (GND)

SMART Payout Connector

The connectors for the SMART Payout can be seen below:

Pin	Name	Type	Description
1	0V	Power	0V Supply (GND)
2 - 8	⚠ Not Used		

Pin	Name	Type	Description
9	+V In	Power	+12/24V DC Supply
10 - 13	⚠ Not Used		
14	TTL Receive (Rx)	Input	Serial Data (optionally link to Pin 1*)
15	⚠ Not Used		
16	TTL Transmit (Tx)	Output	Serial Data (optionally link to Pin 5*)

ccTalk® - DES Encryption

When using ccTalk® DES encryption, the NV200 and host machine must exchange a secret key which forms the basis of the communication encryption. This exchange is performed in a Trusted Mode maintaining security. The Trusted Mode can only be entered by a physical access to the unit. Please refer to [ccTalk® DES Encryption - Trusted Mode](#) for details.

Setup Example Drawings

NV200

The drawing below highlights how to connect the NV200 to a ccTalk host machine using available cables and interfaces from Innovative Technology Ltd.

ⓘ This is not true ccTalk as the Tx and Rx pins are not joined, pin 1 and 5 can be connected if required.

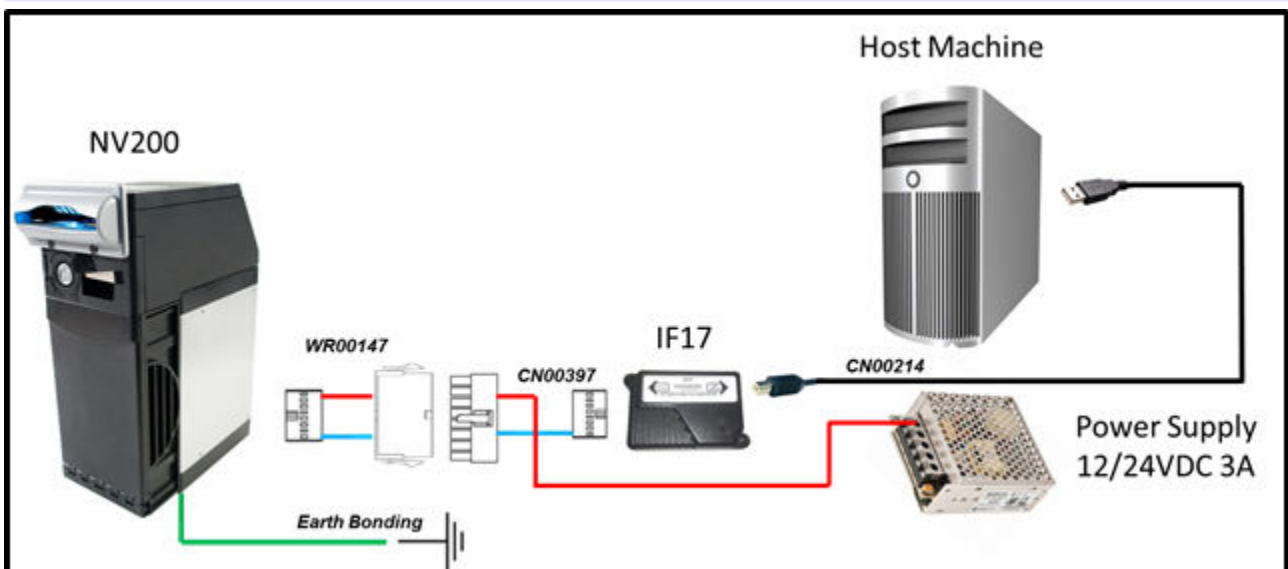

Type	ITL Part Number	Description
Cable	CN00397	SMART Payout to Host Cable

Type	ITL Part Number	Description
Cable	WR00147	SMART Payout to NV200 Adaptor
Cable	CN00214	USB A to B cable assembly
IF17	IF17	IF17 Interface Converter

SMART Payout (Discontinued)

The drawing below highlights how to connect the SPO to a ccTalk host machine using available cables and interfaces from Innovative Technology Ltd.

 This is not true ccTalk as the Tx and Rx pins are not joined, pin 1 and 5 can be connected if required.

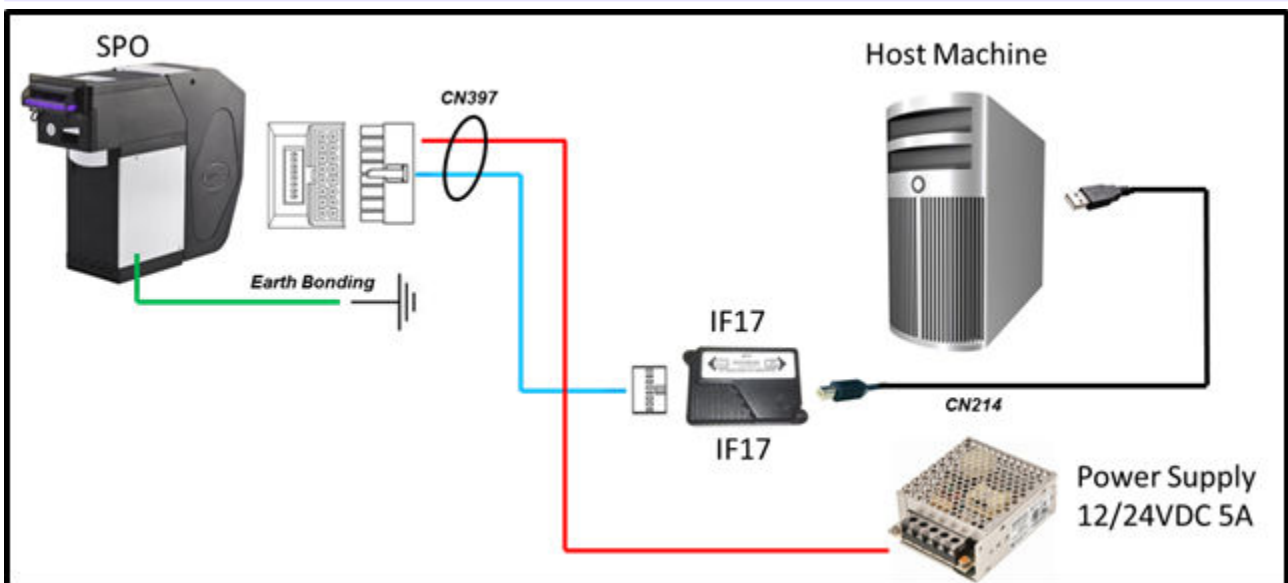

Type	ITL Part Number	Description
Cable	CN00397	SMART Payout to Host Cable
Cable	CN00214	USB A to B cable assembly
IF17	IF17	IF17 Interface Converter

SIO and SI2

General Description

SIO (Serial Input/Output) is a very basic and low level serial communication interface. Messages are not echoed back. SIO uses 300 baud whereby SI2 uses 9600 baud.

 SIO and SI2 are outmoded and not recommended for new developments.

The data is formatted as follows:

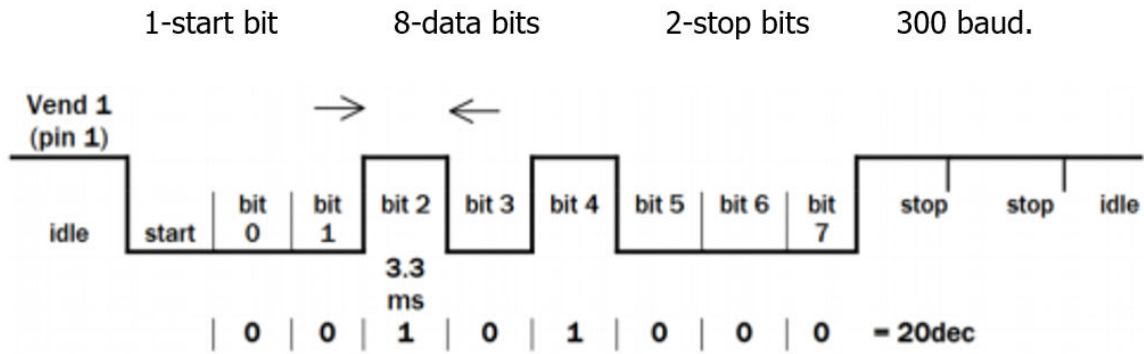

See below a list of recognised Receive and Transmit codes:

Recognised Receive Codes to BV20		Transmitted Codes from BV20	
MESSAGE	DECIMAL VALUE	MESSAGE	DECIMAL VALUE
Inhibit C1	131	Note Accept on C1	1
Inhibit C2	132	Note Accept on C2	2
Inhibit C3	133	Note Accept on C3	3
Inhibit C4	134	Note Accept on C4	4
Inhibit C5	135	Note Accept on C5	5
Inhibit C6	136	Note Accept on C6	6
Inhibit C7	137	Note Accept on C7	7
Inhibit C8	138	Note Accept on C8	8
Inhibit C9	139	Note Accept on C9	9
Inhibit C10	140	Note Accept on C10	10
Inhibit C11	141	Note Accept on C11	11
Inhibit C12	142	Note Accept on C12	12
Inhibit C13	143	Note Accept on C13	13
Inhibit C14	144	Note Accept on C14	14
Inhibit C15	145	Note Accept on C15	15
Inhibit C16	146	Note Accept on C16	16

Recognised Receive Codes to BV20		Transmitted Codes from BV20	
Un-inhibit C1	151	Note Not Recognised	20
Un-inhibit C2	152	Mechanism running slow	30
Un-inhibit C3	153	Strimming attempted	40
Un-inhibit C4	154	Note Rejected (fraud channel)	50
Un-inhibit C5	155	STACKER Full or Jammed	60
Un-inhibit C6	156	Abort During Escrow	70
Un-inhibit C7	157	Note may have been taken to clear jam	80
Un-inhibit C8	158	Validator Busy	120
Un-inhibit C9	159	Validator Not Busy	121
Un-inhibit C10	160	Command Error	255
Un-inhibit C11	161		
Un-inhibit C12	162		
Un-inhibit C13	163		
Un-inhibit C14	164		
Un-inhibit C15	165		
Un-inhibit C16	166		
Enable serial escrow mode	170		
Disable serial escrow mode	171		
Accept escrow	172		
Reject escrow	173		
Status	182		

Recognised Receive Codes to BV20		Transmitted Codes from BV20
Enable all	184	
Disable all	185	
Disable escrow timeout	190	
Enable escrow timeout	191	

Below is an example transaction:

Event	Validator	Decimal Value	Host
Note entered into validator	Validator Busy	120 →	
Note accepted channel 2	Validator Ready	121 →	
	Accept on channel 2	2 →	
Note entered into validator	Validator Busy	120 →	
Note not recognised	Validator Ready	121 →	
	Note not recognised	20 →	
Validator has returned note	Validator Ready	121 →	
Software Inhibit Channel 4	Inhibit C4	← 134	Inhibit C4
	Channel 4 inhibited	134 →	
Software Enable Channel 4	Uninhibit C4	← 154	Uninhibit C4
	Channel 4 inhibited	154 →	
Status Report		← 182	Status Request
	Status Requested	182 →	
3 byte status message	Inhibit status Channels 1-8	Byte 1 →	

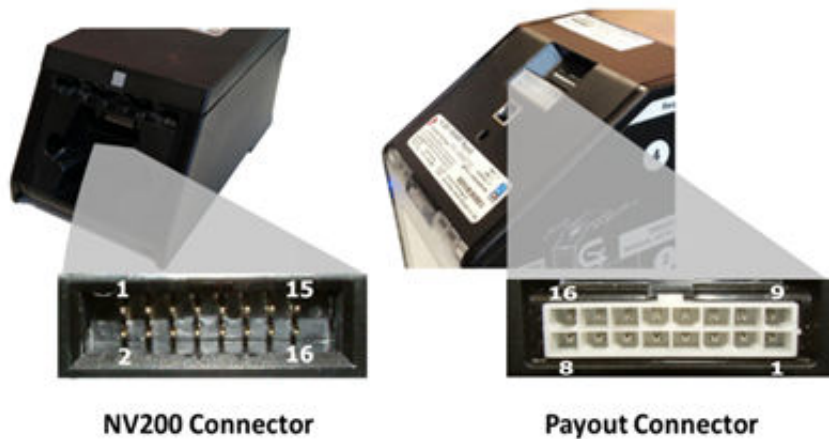

Event	Validator	Decimal Value	Host
	Inhibit status Channels 9-16	Byte 2 →	
	Escrow On (=1) / Off (=0)	Byte 3 →	
Turn on Escrow Mode		← 170	Enable Escrow Mode
	Escrow Mode Enabled	170 →	
Note accept in Escrow Mode			
Note entered into validator	Validator Busy	120 →	
Note Accepted Channel 2	Validator Ready	121 →	
	Accept on Channel 2	2 →	
		← 172	Accept Note in Escrow
	Accept Escrow	172 →	
	Accept on Channel 2	2 →	

Pin Assignments





NV200 Connector

Pin	Name	Type	Description
1	Tx	Output	Serial Data Out (Tx)

Pin	Name	Type	Description
2 - 4	 Not Used		
5	Rx	Input	Serial Data In (Rx)
6 - 14	 Not Used		
15	+V In	Power	+12/24V DC Supply
16	0V	Power	0V Supply (GND)

SMART Payout Connector

Pin	Name	Type	Description
1	0V	Power	0V Supply (GND)
2 - 8	 Not Used		
9	+V In	Power	+12/24V DC Supply
10 - 13	 Not Used		
14	Rx	Input	Serial Data In (Rx)
15	 Not Used		
16	Tx	Output	Serial Data Out (Tx)

MDB

General Description

MDB (Multi-Drop Bus) is an open standard in the vending industry specified by NAMA (National Automatic Merchandising Association) so that all vending and peripheral equipment communicates identically. MDB uses a master-slave model where the VMC (Vending Mechanism Controller) is the master that can communicate with up to 32 slaves (e.g. banknote validator or coin acceptor). Currently only the NV200 and the NV200 with the Payout module are compatible.

Pin Assignments

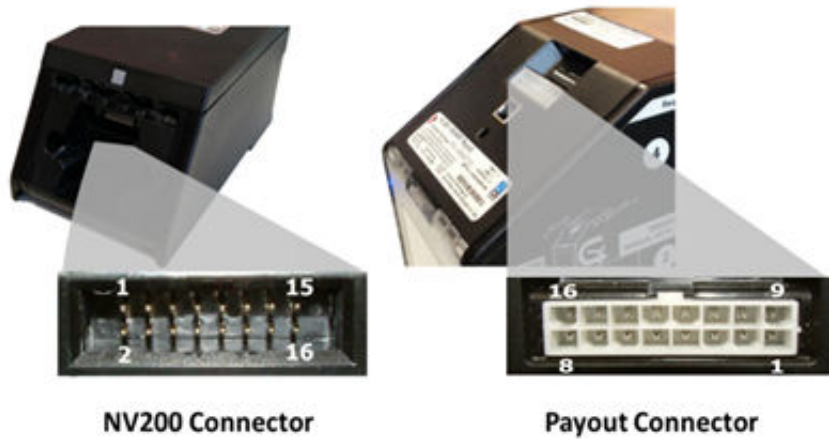

NV200 Connectors

Pin	Name	Type	Description
1	TTL Transmit (Tx)	Output	Serial Data
2	Opto Emitter TXD	Output	Opto-isolated (if connecting directly to host)
3 - 4	⚠ Not Used		
5	TTL Receive (Rx)	Input	Serial Data
6	Opto+ RxD	Input	Opto-isolated (if connecting directly to host)
7	Opto Collector TxD	Output	Opto-isolated (if connecting directly to host)
8 - 9	⚠ Not Used		
10	Opto- RxD	Input	Opto-isolated (if connecting directly to host)
11 - 14	⚠ Not Used		
15	+V In	Power	+12/24V DC Supply
16	0V	Power	0V Supply (GND)

IF5 Interface

The IF5 allows the NV200 to operate with MDB machines no matter the voltage (24/34/48). As the NV200 can operate at 24V this is only required for applications higher than 24v.

Type	ITL part number	Description
Interface	PA02061	IF5 KIT - MDB Voltage Converter

Pulse

General Description

Pulse can be used for the acceptance of up to 16 channels. When a note is recognised vend 1 (pin 1) will pulse a pre-set number of times. The amount of pulses as well as the high/low pulse ratio is configurable.

 Pulse is an insecure interface and should not be used for new developments.

 The Pulse interface is not in the standard NV200 files and may be made available subject to commercial justification. A request should be made to support at support@innovative-technology.com

Pin Assignments



NV200 Connector

Pin	Name	Type	Description
1	Vend 1	Output	Credit Output Pulse
2 - 4	 Not Used		
5	Inhibit 1	Input	Inhibit Input Channel 1
6	Inhibit 2	Input	Inhibit Input Channel 2
7	Inhibit 3	Input	Inhibit Input Channel 3
8	Inhibit 4	Input	Inhibit Input Channel 4
9	Busy	Output	Output Busy Signal
10	Escrow	Input	Input Escrow Control

Pin	Name	Type	Description
11 - 14	⚠ Not Used		
15	+V In	Power	+12V DC Supply
16	0V	Power	0V Supply (GND)

Inhibit Control

The Inhibits can be used to either enable or disable the acceptance of those banknotes programmed on channels 1, 2, 3 and 4. The Inhibits are internally held high and must be set to low (GND) to enable banknote acceptance. If no Inhibit is set to low (GND) the Master Inhibit is set and the NV200 is disabled.

Escrow Control

The NV200 has a single note escrow facility. This allows the Validator to hold onto the note once accepted, and only stack the note into the cash box when the host machine confirms that the vend operation has been completed. If no confirmation of vend is received then the note will be returned to the customer after 30 seconds.

Busy Control

When the busy line is high the unit is in the process of accepting a note, and a vend signal is likely to appear shortly afterwards.

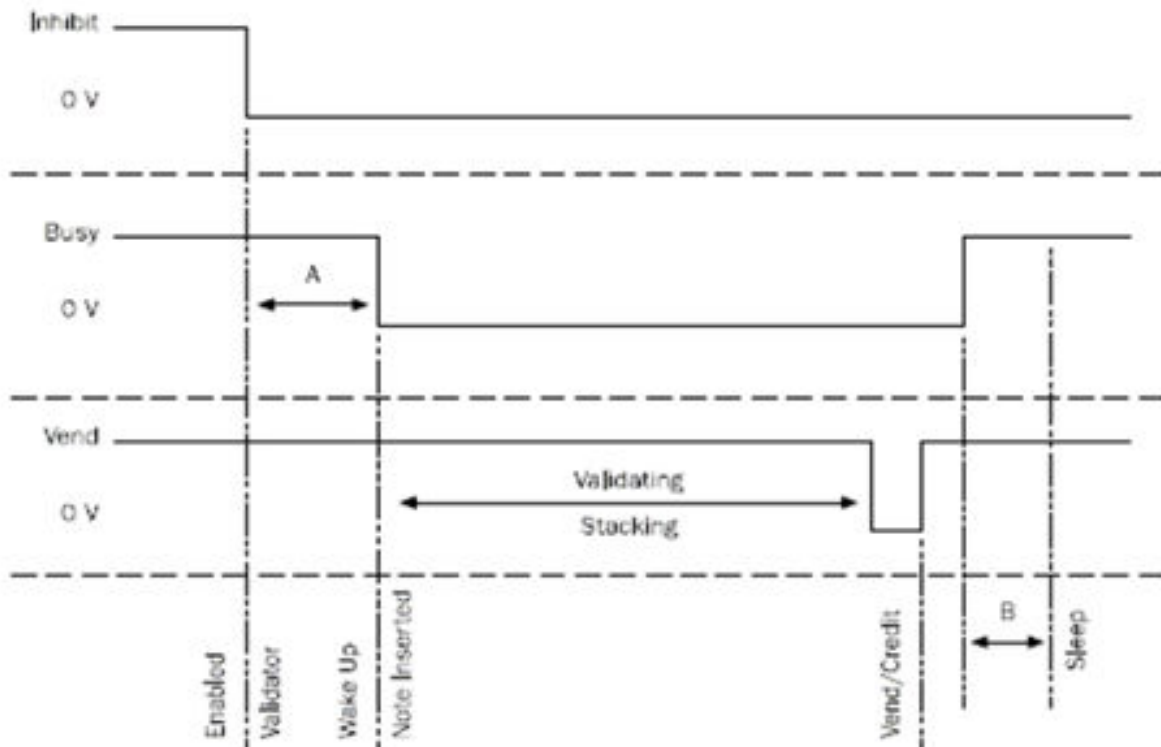

IF15 Interface

The IF15 is an interface that allows serial SSP to be used in machines without the need of updating the machine software. The IF15 is connected between the NV200 and the host machine. The IF15 communicates with the NV200 in serial SSP which gives more security along the length of the cable. The IF15 should be mounted close to the host

machine control board where the IF15 converts to the pulse connection. If the inhibits aren't required connect them all to the GND line, it will leave all the channels constantly enabled.

Type	ITL part number	Description
Interface	PA02321	IF15 Kit – SSP to Pulse

NV200 Range Service Guide

Contents

- Routine Maintenance
 - Introduction
 - Recommended Cleaning Intervals
 - Cleaning the Validator
 - Bezel LED Flash Codes
 - Payout Module Flash Codes
 - Checking Power Connections
 - NV200 Connector
 - SMART Payout Connector
 - Checking the Supply Voltage
 - Communication with the Host
 - Clearing a Jam within the NV200
 - Note is in the note path
 - Note is visible once the NV200 has been removed
 - Note isn't visible once the NV200 has been removed
 - Clearing a Jam from a Standard Cashbox
 - Clearing a Jam from the Payout Module
 - Diverter and Tape Positions in the Payout Module
 - Testing After an Error Has Been Cleared
-

Routine Maintenance

Introduction

Depending upon the environment the NV200 is running in it may require cleaning or note path clearing.

Recommended Cleaning Intervals

Clean the optical lenses every 6 months or more if the unit is in a particularly harsh environment. Dirt, dust or other residue leads to bad note acceptance and other performance degradation. Please refer to the section below for comprehensive cleaning instructions.

Cleaning the Validator



Do not use solvent based cleaners on any part of the NV200 unit.

Do not use solvent based cleaners such as alcohol, petrol, methylated spirits, white spirit or PCB cleaner. Using these solvents can cause permanent damage to the units; only use a mild detergent solution as directed below.

The NV200 note path can be cleaned with the head still fitted to the chassis, although it may be easier to remove the head from the chassis assembly.



Disconnect power BEFORE taking off the head to avoid hotplugging.

To remove the NV200 head unit, first lift the silver head release catch located on the front of the NV200. Finally, slide the head unit forward and lift it off the chassis.

- Disconnect power BEFORE any cleaning operation



To open the note path cover, pull the top cover release latch forward (towards the bezel) and lift the cover as shown below (it is recommended to also remove the bezel to allow correct cleaning of the note path guides):



The note path is visible and can be cleaned. Carefully wipe the surfaces with a soft lint free cloth that has been dampened (NOT wet) with a water and mild detergent solution (e.g. household washing up liquid) - be very careful when cleaning around the sensor lenses and make sure they are clean and dry before closing the cover and powering the unit.

- Do not use any lubricants.
Do not lubricate any of the note transport mechanism or any part of the note path, as this can affect the operation of the validator.
- Do not try to disassemble.
Do not attempt to disassemble the validator head – trying to do this could cause personal injury and will damage the unit beyond repair.

Bezel LED Flash Codes

If there is a configuration or other error, the NV200 bezel will flash a pattern to indicate what error it is experiencing. A summary of the Bezel Flash Codes for the NV200 is below:

Flashes		Indicated Status / Error	Recommended Action
Red	Blue		
1	1	Note Path Open	Close the lid of the NV200 validator it will click into place as it shuts.
	2	Note Path Jam	<div style="background-color: #e6e6ff; padding: 5px; border: 1px solid #ccc;">  Disconnect power BEFORE taking off the head to avoid hotplugging. </div> <p>Power down the NV200</p> <p>Open the NV200 using the silver catch on top and inspect the note path for any note debris</p> <p>If there isn't any evidence of a note carefully remove the NV200 from the base using the silver catch on the front.</p> <p>A note could be just sticking out from the cashbox, remove power and the NV200 head.</p> <p>If a note is visible remove the note.</p> <p>Re-attach the head and power.</p>
	3	Unit Not Initialised	Initialise the unit.
	4	Straightener Mechanical Failure	Check straightener mechanism
2	1	Cashbox Removed	Insert the cashbox.
	2	Cashbox Jam	Follow the steps as advised here.
	6	Currency Mismatch	Remove the current TEBS bag and reinsert a new bag.
	7	Firmware Error	Please contact ITL support.
3	1	Firmware Checksum Error	There has been an issue with the attempted download, retry the download with the recovery section on validator manager, if this fails arrange for the unit to be returned to the nearest repair centre; details of which can be found on our website.
	2	Interface Checksum Error	The firmware loaded doesn't contain the primary interface from the previous firmware. Download with the IF file containing the correct protocol.
	3	EEPROM Checksum Error	There has been an issue with the attempted download, retry the download with the recovery section on validator manager, if this fails arrange for the unit to be returned to the nearest repair centre; details of which can be found on our website.
	4	Dataset Checksum Error	

4	1	Power Supply too Low	Check the voltage on your power supply is within the specified voltage range as outlined here . If the voltage appears to be correct, please check to ensure the power supply voltage doesn't vary by more than 10% under maximum current draw.
	2	Power Supply too High	Check the voltage on your power supply is within the specified voltage range as outlined here . If the voltage appears to be correct, please check to ensure the power supply voltage doesn't vary by more than 10% under maximum current draw.
	3	Card Format	The data card inserted is incorrect, format the card using the latest NVCardUtilities.
	4	Payout Reset	The Smart Payout is in the process of resetting, wait for it to recover.
5	1	Firmware Mismatch	The Firmware on the device connected doesn't match the firmware on the NV200. Ensure the Firmware supports the connected device. If a payout is connected, ensure Dipswitch 7 is off.
	2	Payout Jam	The smart payout has encountered an issue and a note has jammed, follow the steps as described here .
	4	Payout Jam recovery in progress	The smart payout encountered a jam and is attempting to recover. 5 notes will be moved to the cashbox, from the payout. Once the unit has completed this it will go back in service.

Payout Module Flash Codes

An LED on the rear of the payout module can flash error codes to aid troubleshooting.

Status Indicator		Flash es	Indicated Error	Recommended Action
Red	Green			
		0	No LEDs lit	Ensure the required power is being provided.
RED		1	Motor / barcode error	Arrange for the unit to be returned to the nearest repair centre; details of which can be found on our website.
RED		2	Note sensor error	
RED		3	EEPROM error	
RED		4	Payout jammed	Remove trapped note.

RED		5	Diverter error	Switch Payout module DIP switch 8 on and off with power on .
RED	GREEN	0	Both LEDs on (no flash)	Turn power on and off.
RED	GREEN	1	Power reset	Providing information, not an error.
RED	GREEN	2	Wakeup from low power	Providing information, not an error.
RED	GREEN	3	Software reset	Providing information, not an error.
RED	GREEN	4	Software command	Providing information, not an error.
RED	GREEN	5	User manual reset	Providing information, not an error.
RED	GREEN	6	Power supply issue	Check power supply is within specification
RED	GREEN	7	Unknown cause	Ensure the unit is grounded.
	GREEN	1 every second	None	Providing information, not an error

Checking Power Connections

Check to ensure the power cables are correctly connected to the unit as shown below:



Disconnect power BEFORE taking off the head to avoid hotplugging.

NV200 Connector

Ensure the NV200 has power applied.



The NV200 connector and the IF17 connector are similar, the only difference is the power cables in pins 15 & 16 on the NV200 connector.



SMART Payout Connector

The Payout module connector is a 16-pin molex.



If the TEBS cashbox is fitted it also needs to be connected to power as explained in the section above.



Checking the Supply Voltage

If the power supply seems to be powered and connections to the unit are in place, yet the unit isn't powered, check the voltage output from the power supply is sufficient and the polarity is correct.

 Disconnect power BEFORE taking off the head to avoid hotplugging.

If this isn't the issue replace the cable as it may have been damaged.

Should this not resolve the issue, contact your local repair centre, details of which can be found on our website.

Communication with the Host

If there is no communication with the host check the communication cable, typically this will be the IF17 and the port on the host system.

Ensure the cable is connected to the IF17 correctly, so the connectors are fully seated and the USB cable is connected to the computer.



If the unit is connected, enter device manager and check the active com ports, there should be a device labelled as USB Serial.

If no com port is present replace the IF17 and a new device will register.

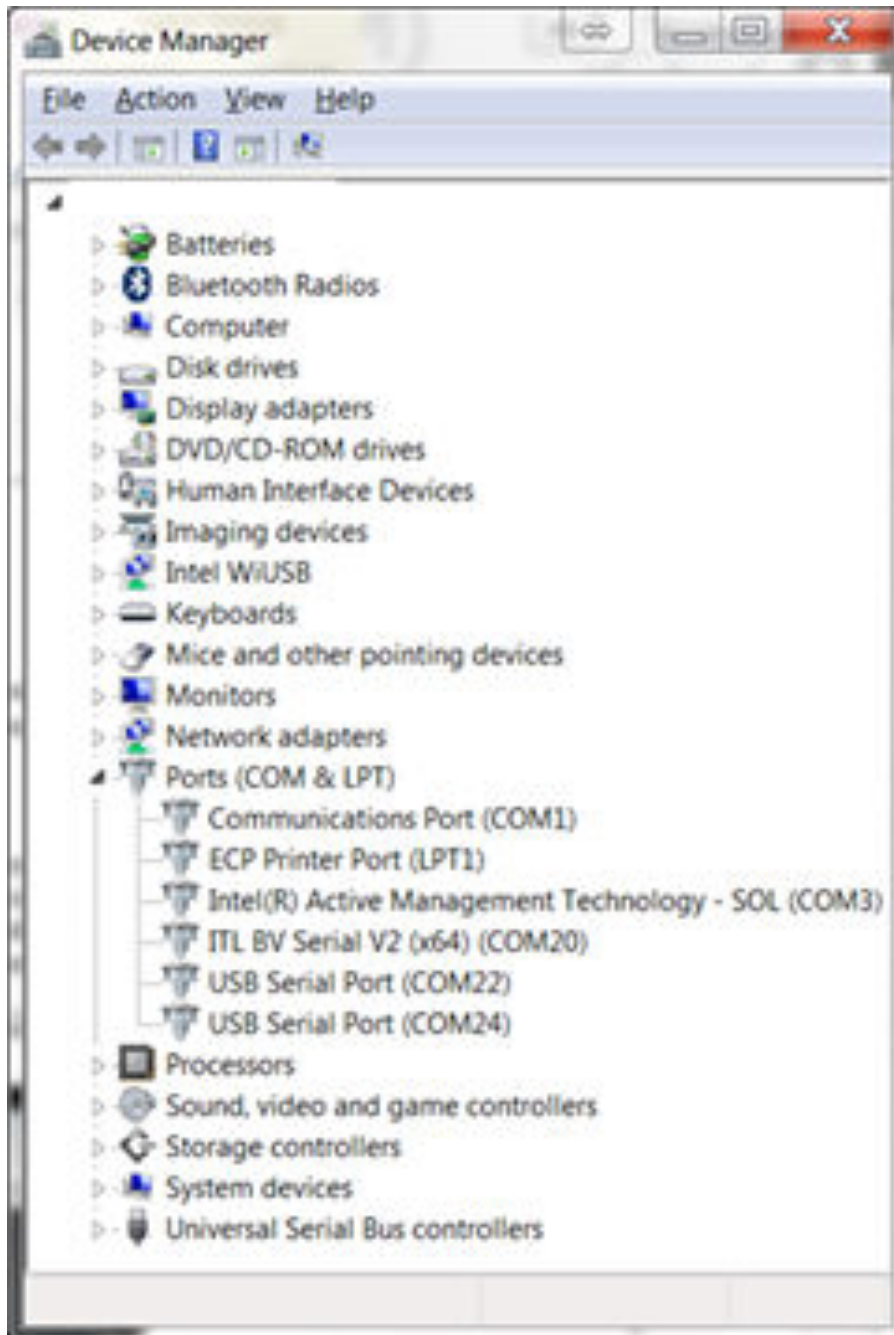

Check the connection to the host software, if there is still an issue replace the IF17 or switch com ports on the PC. If the unit is detected but there is a yellow triangle next to the serial port then the drivers should be reinstalled.

For linux use the dmesg console command as shown below:

```
james@james-VirtualBox ~  
File Edit View Search Terminal Help  
james@james-VirtualBox ~ $ dmesg | grep tty  
[ 0.000000] console [tty0] enabled  
[ 55.387744] usb 1-2: FTDI USB Serial Device converter now attached to ttyUSB0  
james@james-VirtualBox ~ $
```

Clearing a Jam within the NV200

Note is in the note path

Open the note path by pulling the top catch forwards as shown below. Carefully pull the note out of the unit.

Shut the head, the unit will reinitialise indicating the jam has been removed.

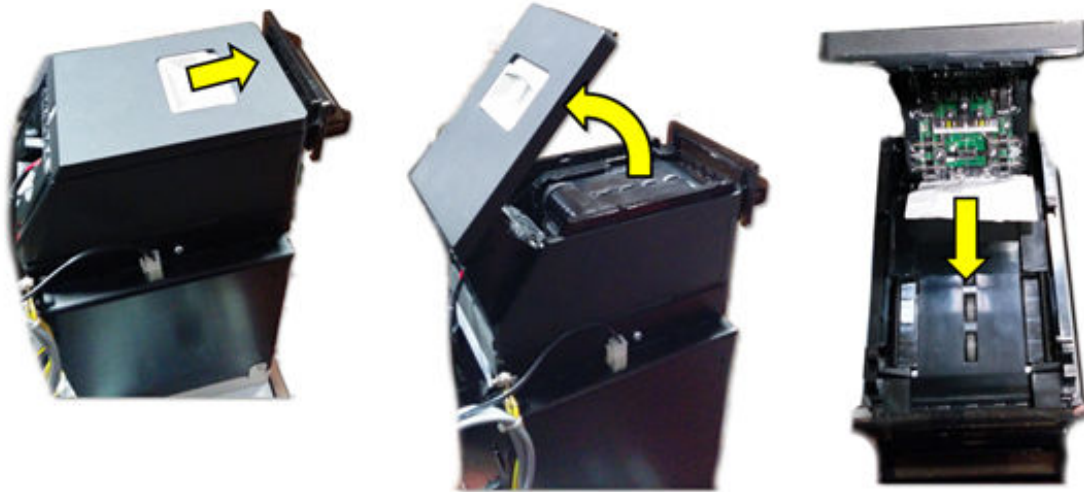

Note is visible once the NV200 has been removed

 Disconnect power BEFORE taking off the head to avoid hotplugging.

Disconnect power and remove the NV200 head, by lifting the silver catch below the bezel and pull the validator forwards, when out of position the validator can be lifted off the cashbox. This jam can be cleared by winding the drive gears on the left of the unit and slowly pulling the note out. Replace the NV200 head and reconnect the power.

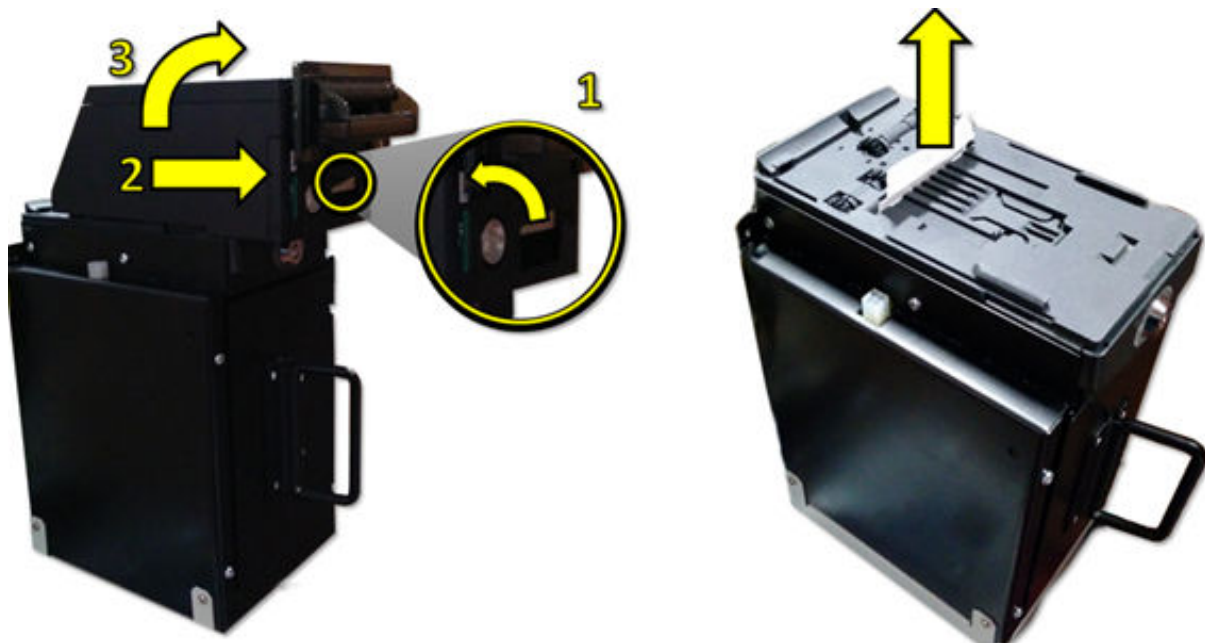

Note isn't visible once the NV200 has been removed

If the note isn't visible when the head is removed the jam is in the cashbox.

To clear a jam in the cashbox follow the relevant cashbox explanation below.

Clearing a Jam from a Standard Cashbox

When no note is visible simply remove the cashbox, then open the cashbox.

Remove any visible jammed notes or debris, if no debris is visible then move the stacker plate back, this will reveal the note drive mechanism any jammed note should now be visible. Remove the jammed note taking care not to

leave any debris inside the unit. Once you believe the jam has been cleared close the cashbox and reinsert the cashbox into the NV200 chassis.

The unit should now restart.

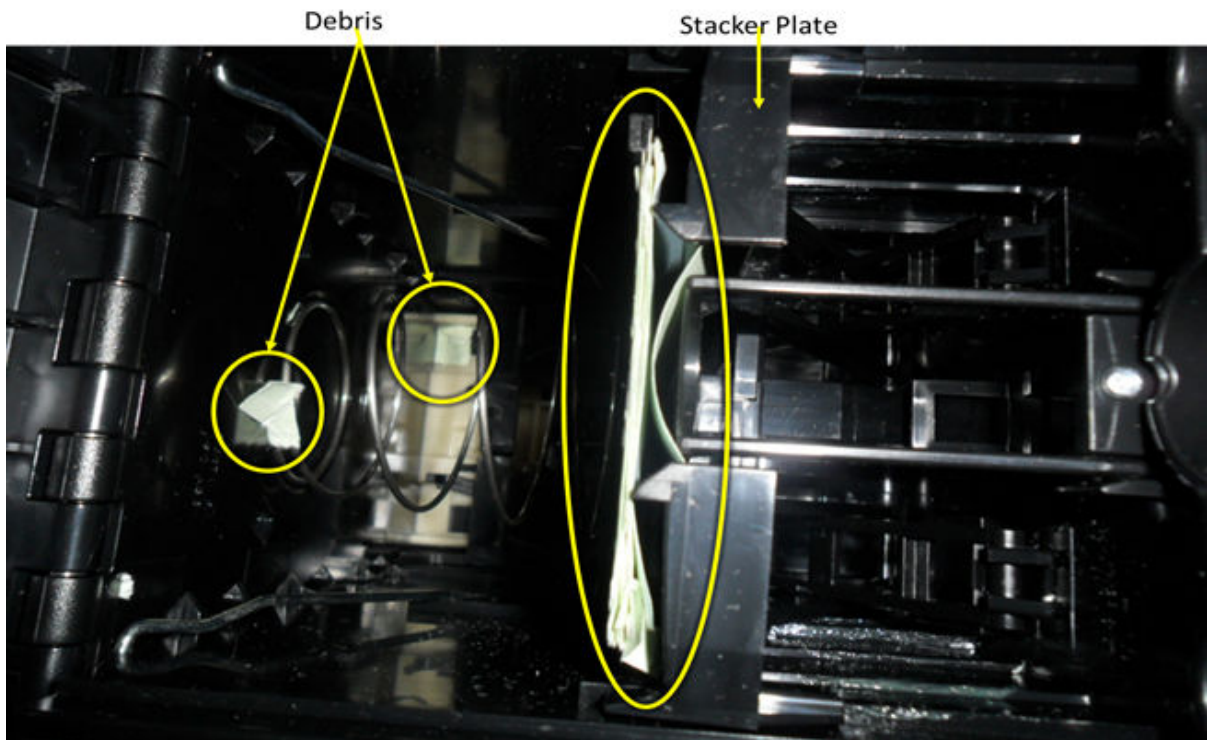

Clearing a Jam from the Payout Module

In case of a Jam in a payout notes can be manually paid out. The payout will need to be removed from the NV200 by lifting the silver catch at the front of the NV200 and sliding it away from the cashbox, it is now possible to lift the payout module away. The only tool required to carry out this process is a 5 mm Allen key.

- Take great care not to overwind the mechanism or force past the dead stops – if done the payout unit will be damaged beyond repair.

Locate the Allen key into the hexagonal Diverter slot.



Move the Diverter into the transfer position by gently turning the Allen key anti-clockwise until it reaches the dead stop.



Locate the Allen key into the hexagonal Motor Drum slot.



Transfer all the stored bank notes onto the Transaction Drum by turning the Allen key clockwise. The barcode will be travelling towards the note exit and the bank notes will be travelling into the module.



Once all the bank notes have been transferred to the Transaction Drum move the Diverter into the payout position by gently turning the Allen key clockwise until it reaches the dead stop.



Pay out the stored bank notes by turning the Allen key anti-clockwise. The barcode will be travelling into the payout module and the bank notes will be paid out through the note exit.



Diverter and Tape Positions in the Payout Module

The images below show the barcode tape position with the diverter in the open and closed positions.

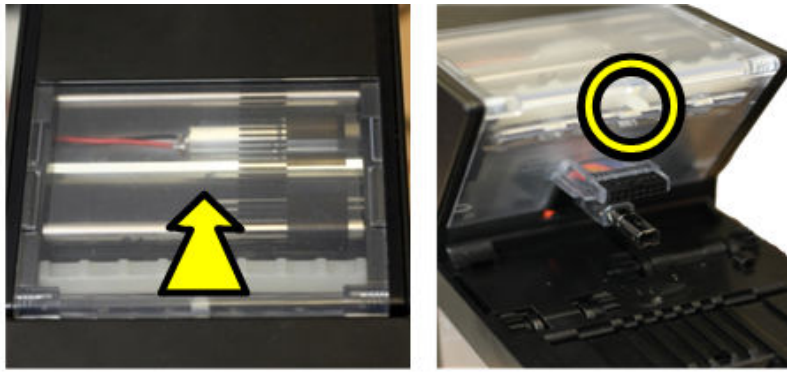

Normal tape position – diverter in CLOSED

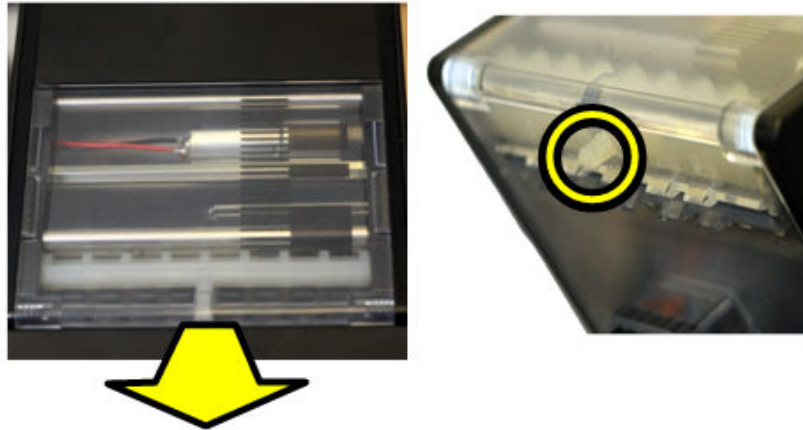

Normal tape position – diverter in OPEN position

Testing After an Error Has Been Cleared

Once an error has been cleared, ensure the device is tested by inserting bills and paying out notes/tickets where applicable. A recommended test is 10 notes in and 10 notes/tickets out, this will help limit the number of repeat calls for the same issue.

NV200 Range Product Compliance



EC Declaration of Conformity

The NV200 family is fully compliant with major standards including but not limited to:

- UL
- CE
- UKCA
- WEEE
- IEC CB

Central Bank Approval

As part of continual product improvement central banks are regularly visited to gain product certification. This includes but is not limited to the following ECB, BoE & FED.

NV200 Range Appendix

Contents

- 2D Drawings
 - NV200
 - NV200 with Payout Module
 - Energy Profiles
 - NV200 Standard Cashbox
 - 12 Volts
 - NV200 with Payout Module
 - 12 Volts
 - 24 Volts
 - Lock Specifications
 - NV200 Locking Cam
 - Cable Drawings
 - Switching to Programming Mode (SSP)
 - Changing the Cashbox Flag in the NV200
 - Freefall Cashbox Advice
 - ccTalk DES Encryption - Trusted Mode
 - Escrow
 - Multi-Escrow
 - File Naming Convention
-

NV200 with Payout Module

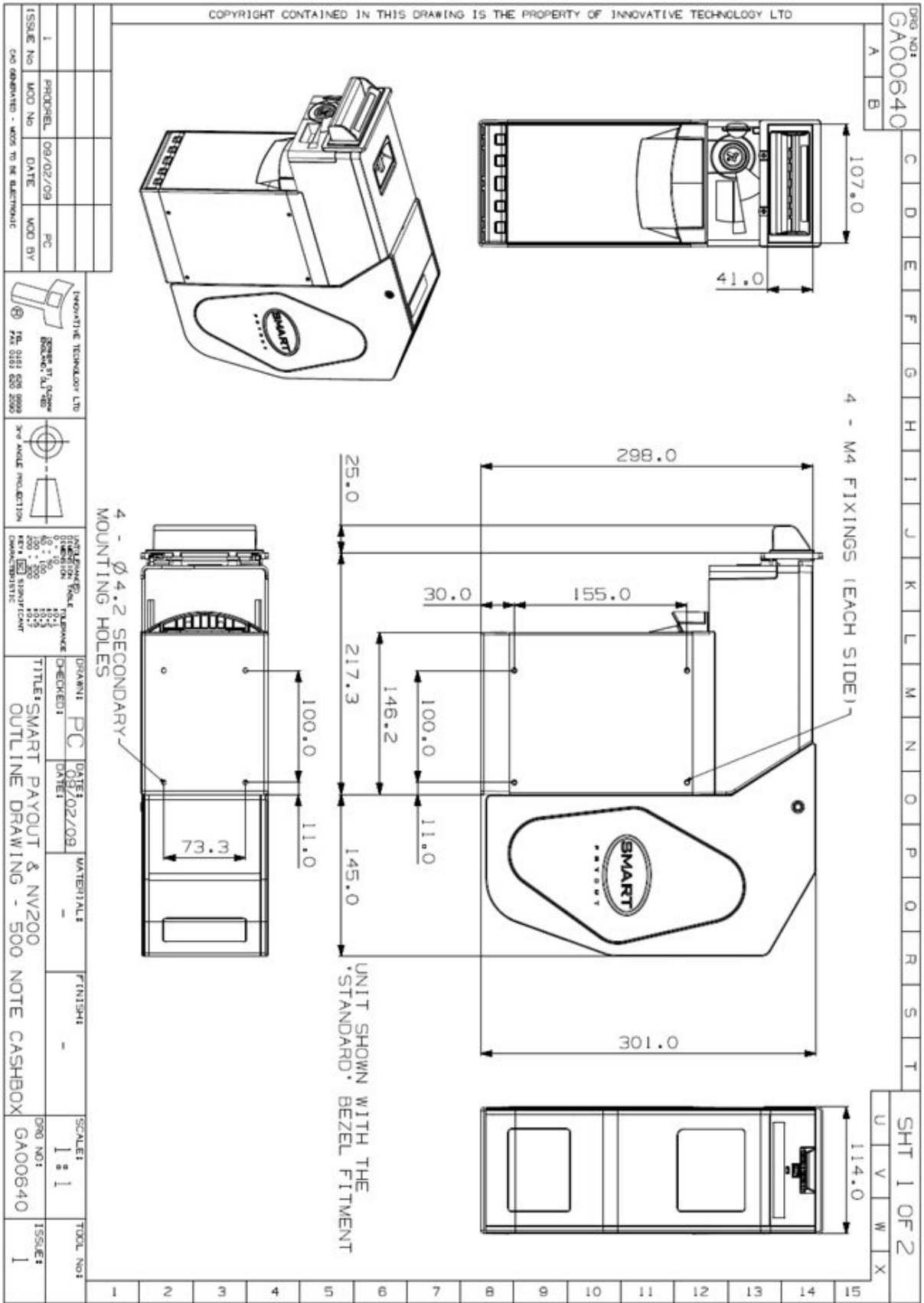

Energy Profiles

NV200 Standard Cashbox

12 Volts

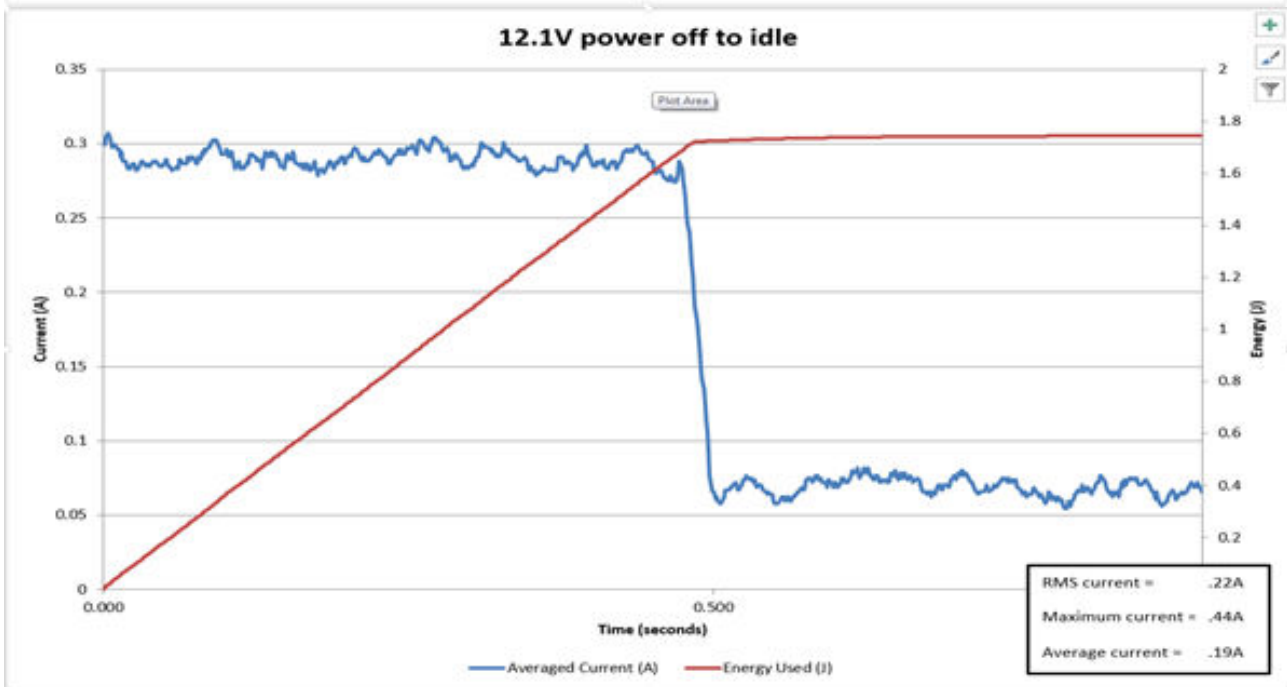
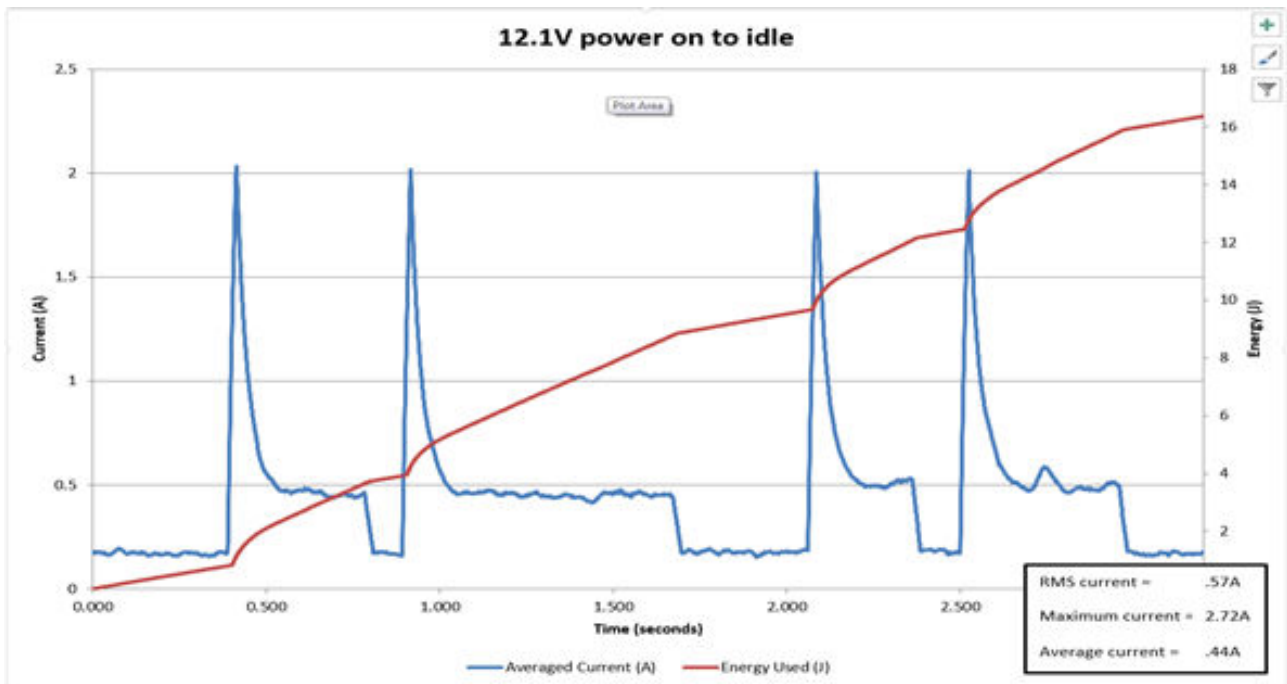

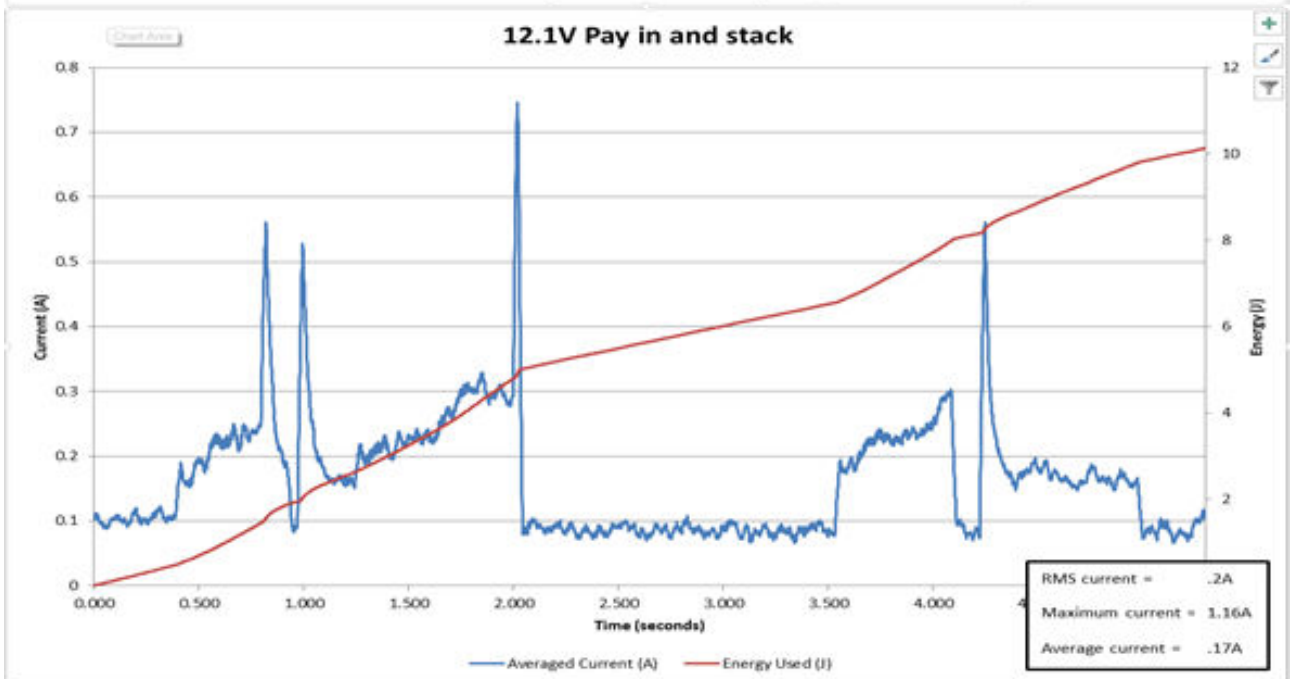
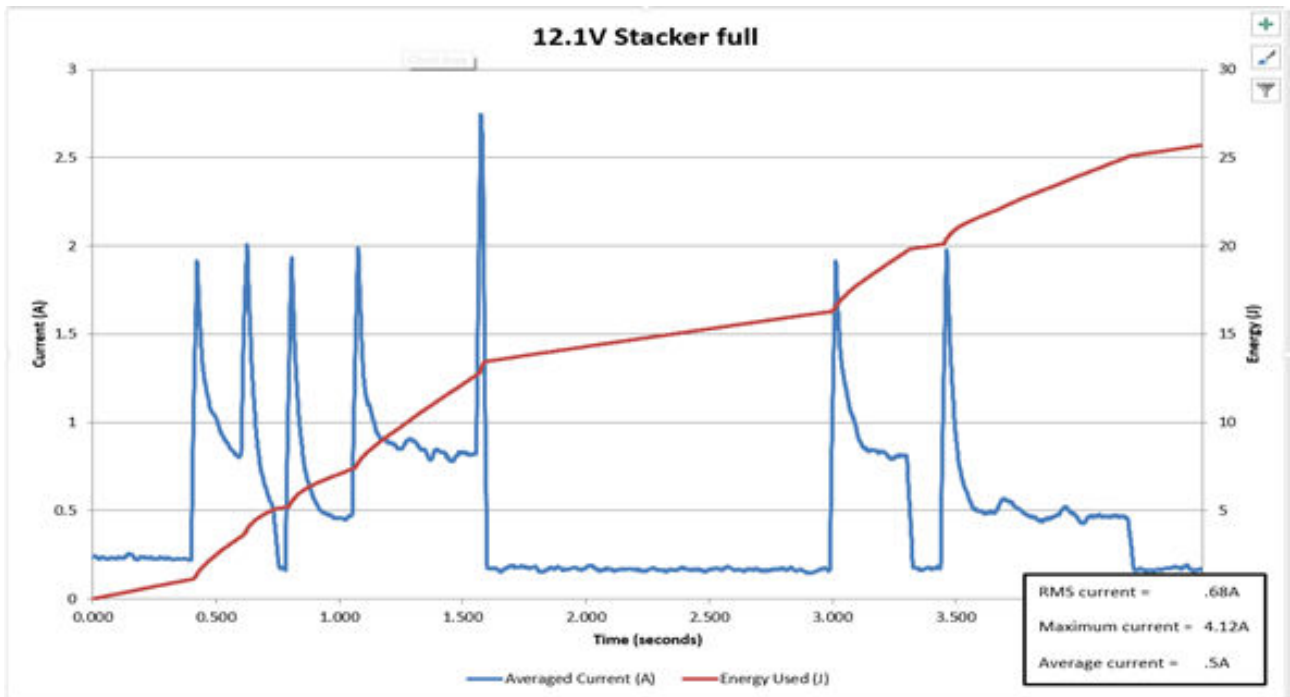

NV200 with Payout Module

12 Volts

Power off to idle

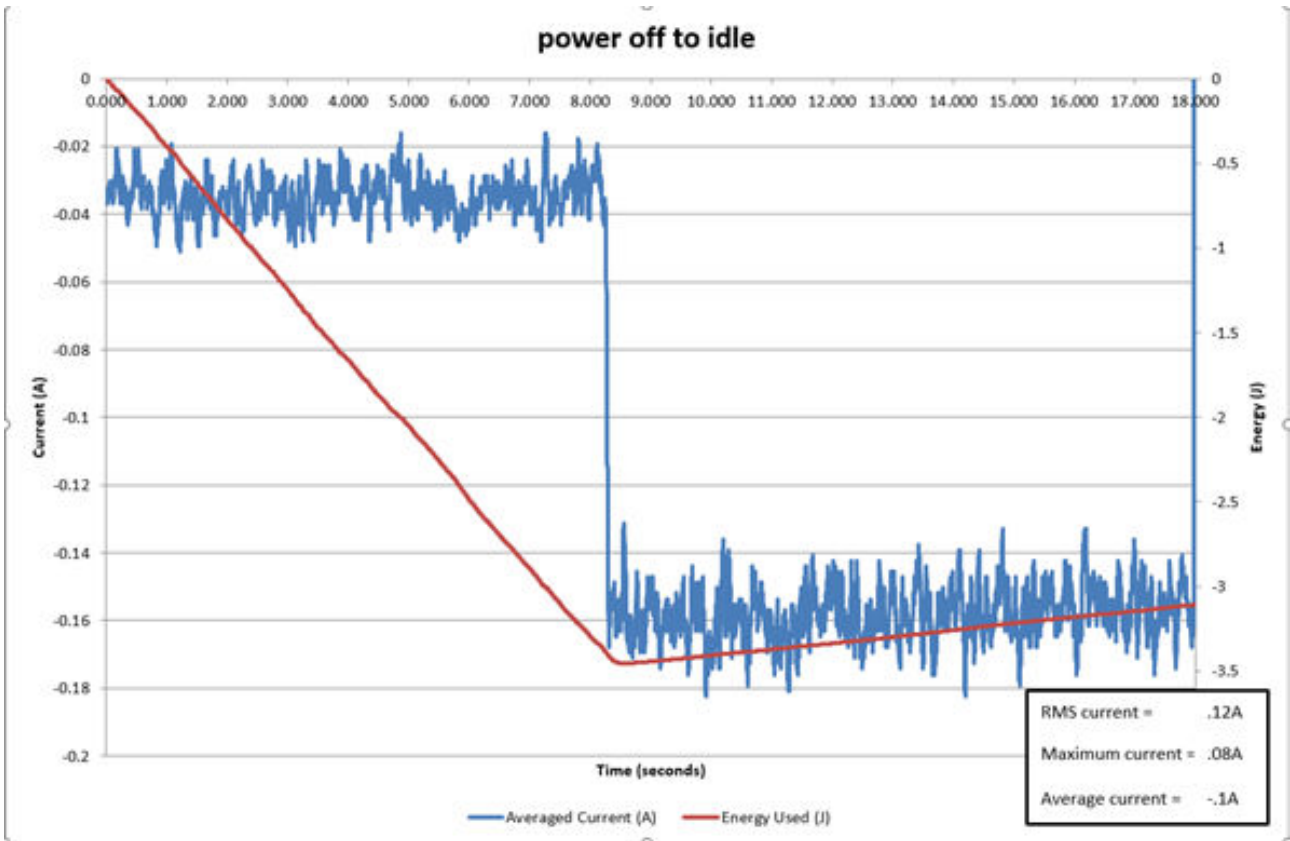

Power on to idle

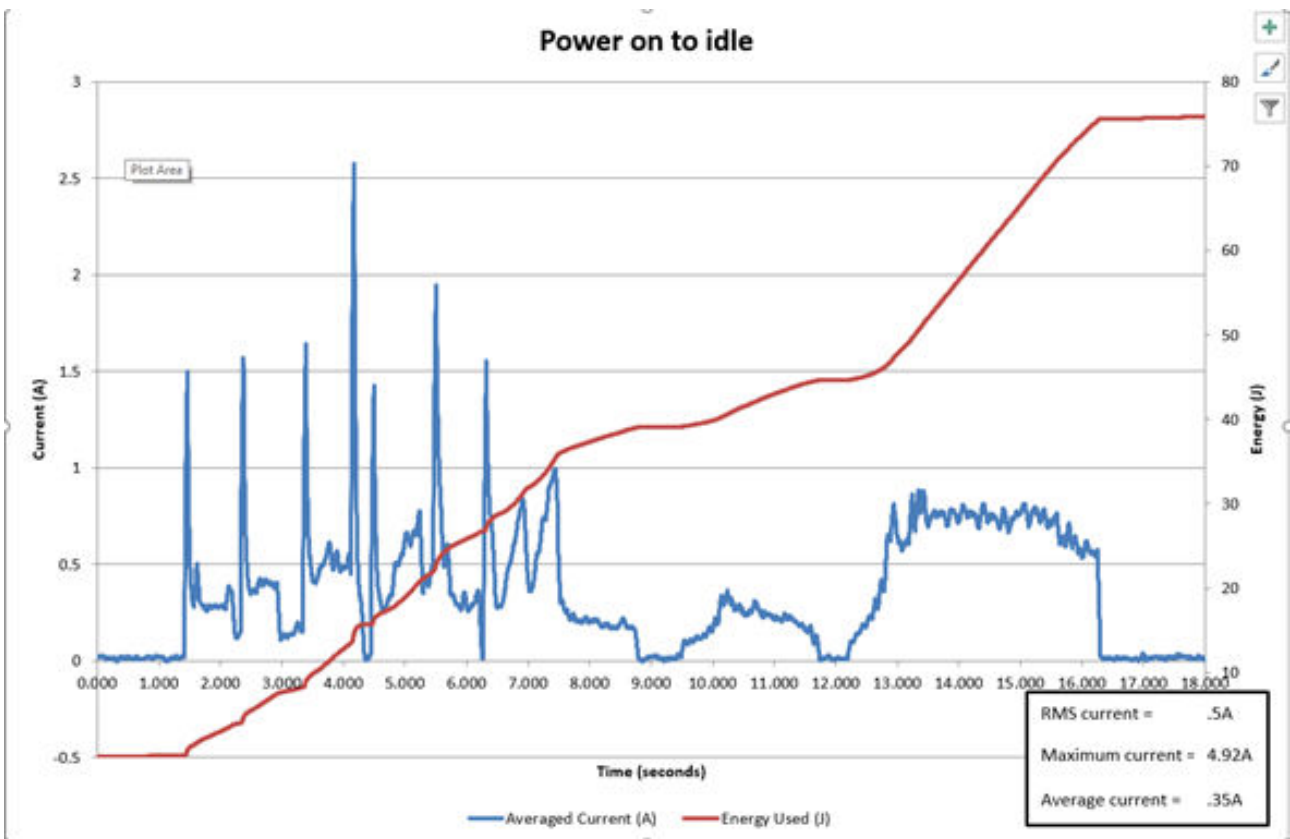

10 second idle

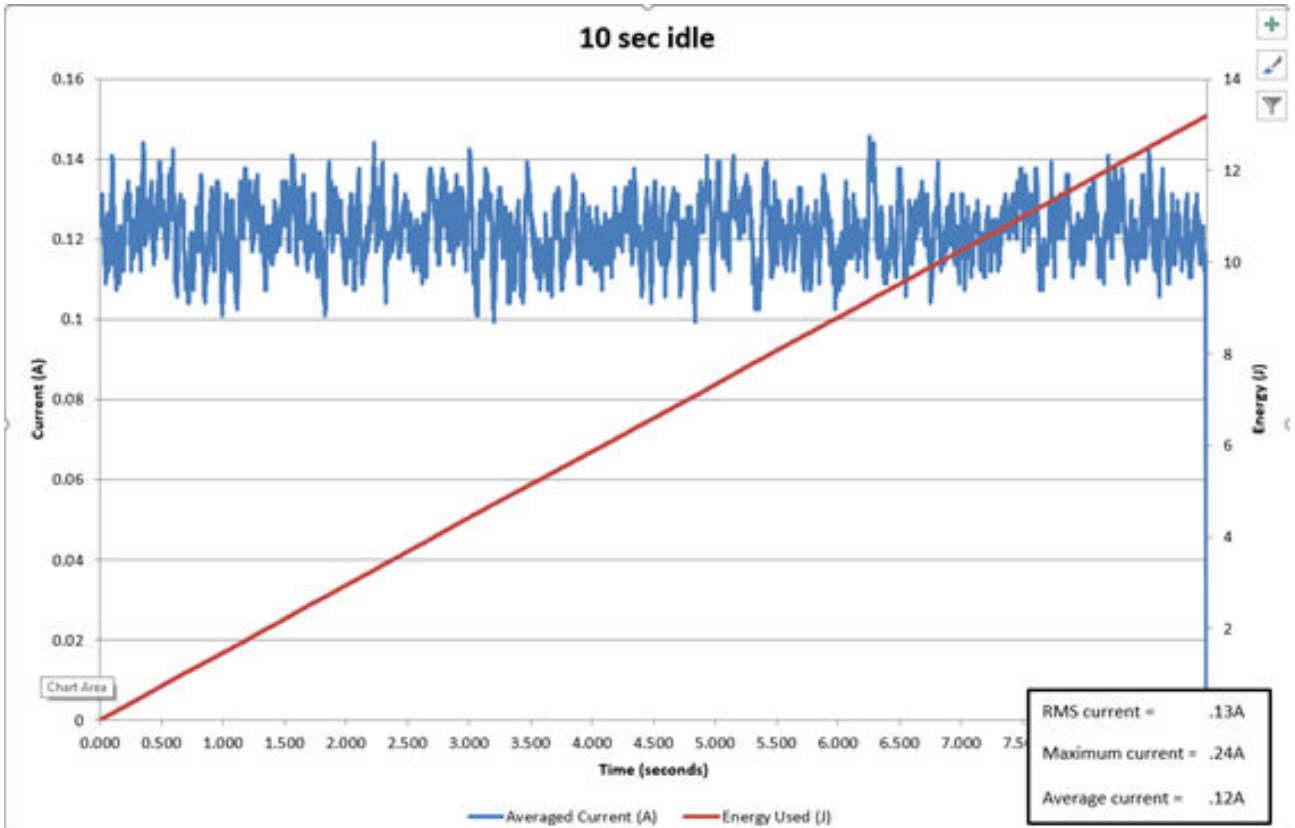

Note insert and stored

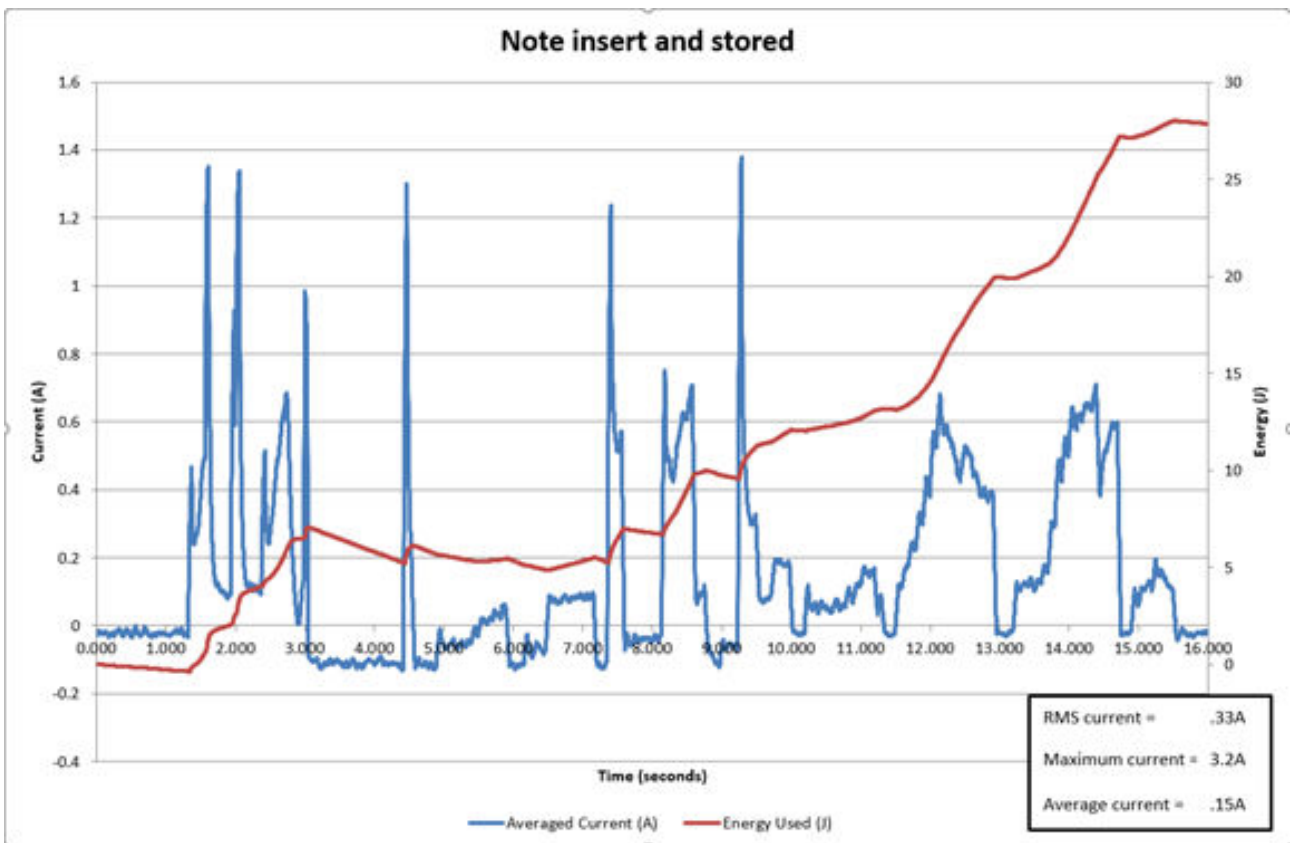

Note insert and reject

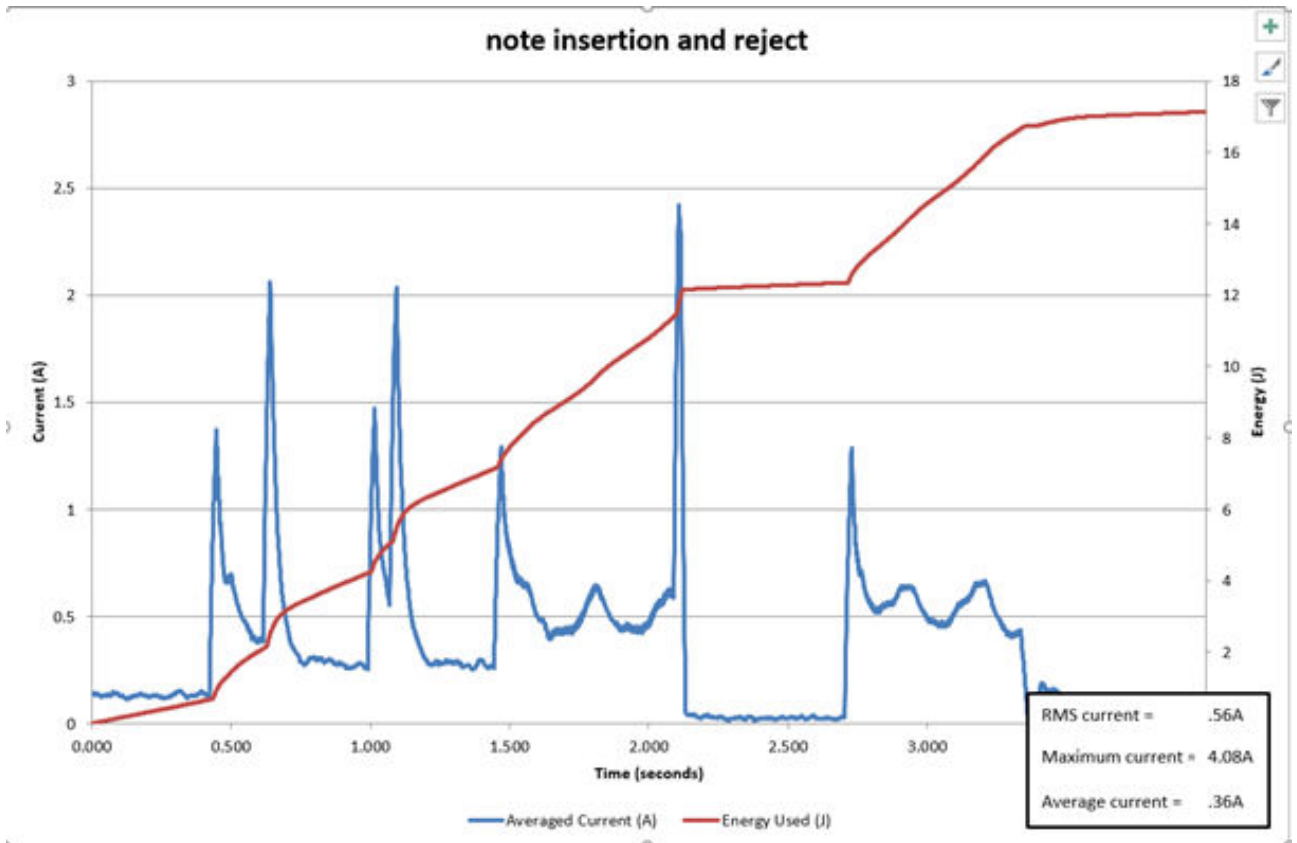

Note paid out

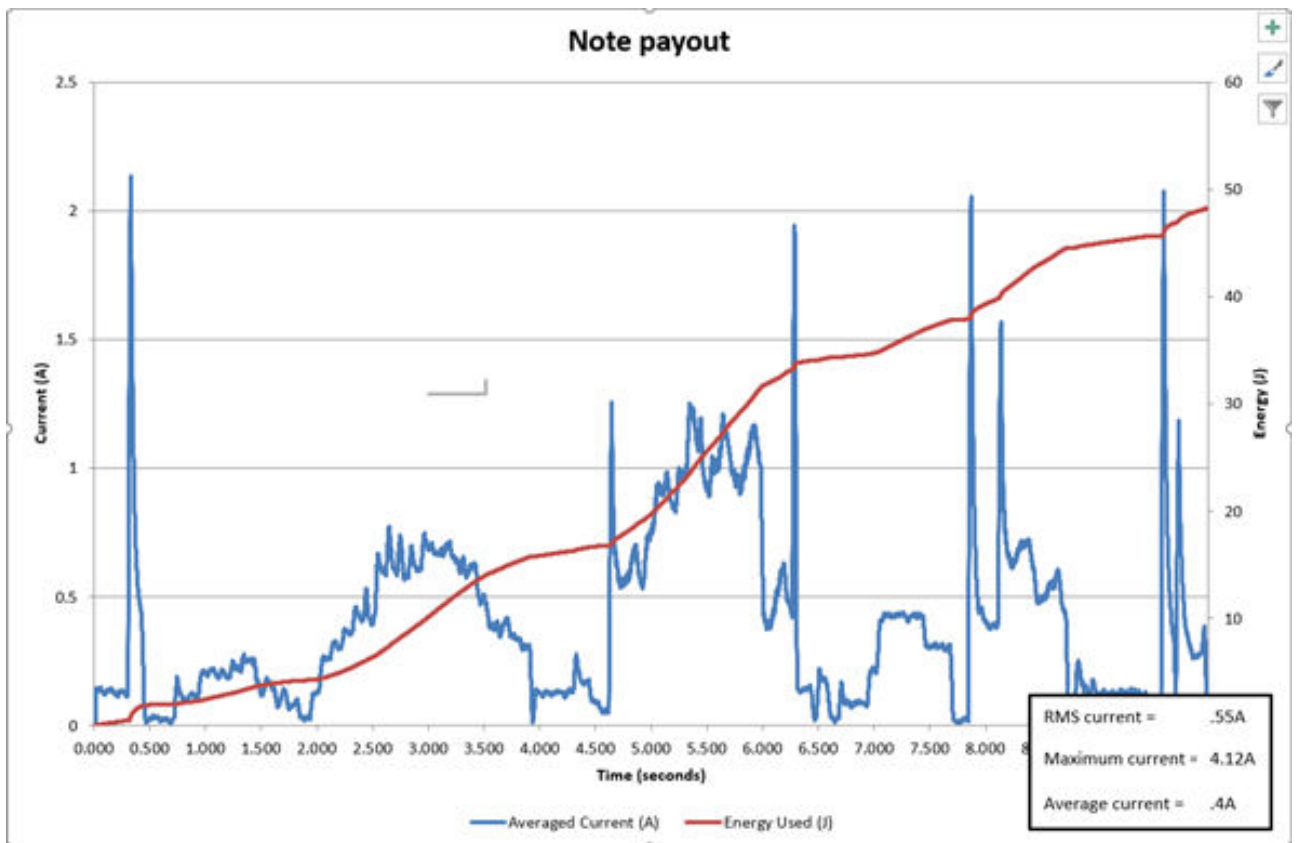

Anti-Jam Routine

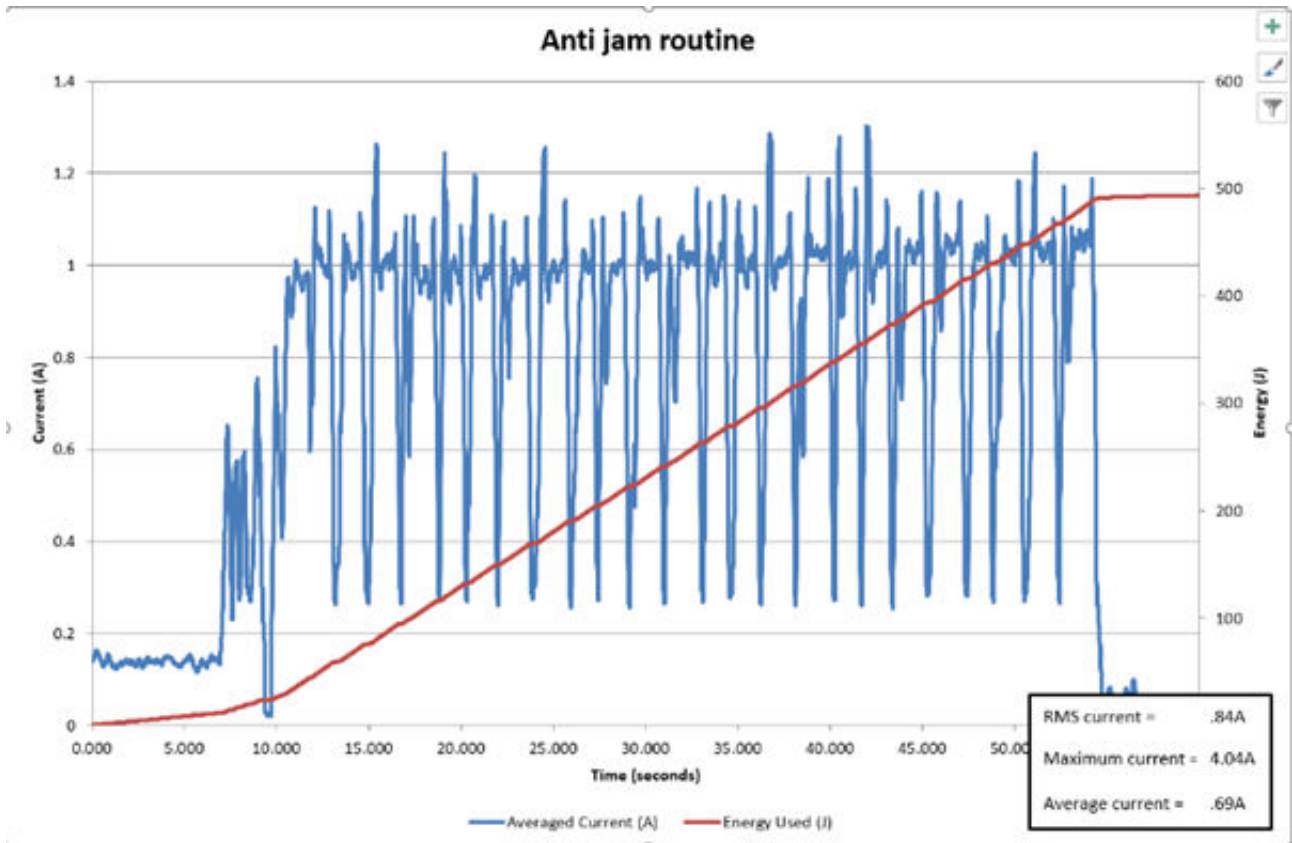

SMART Payout Jam

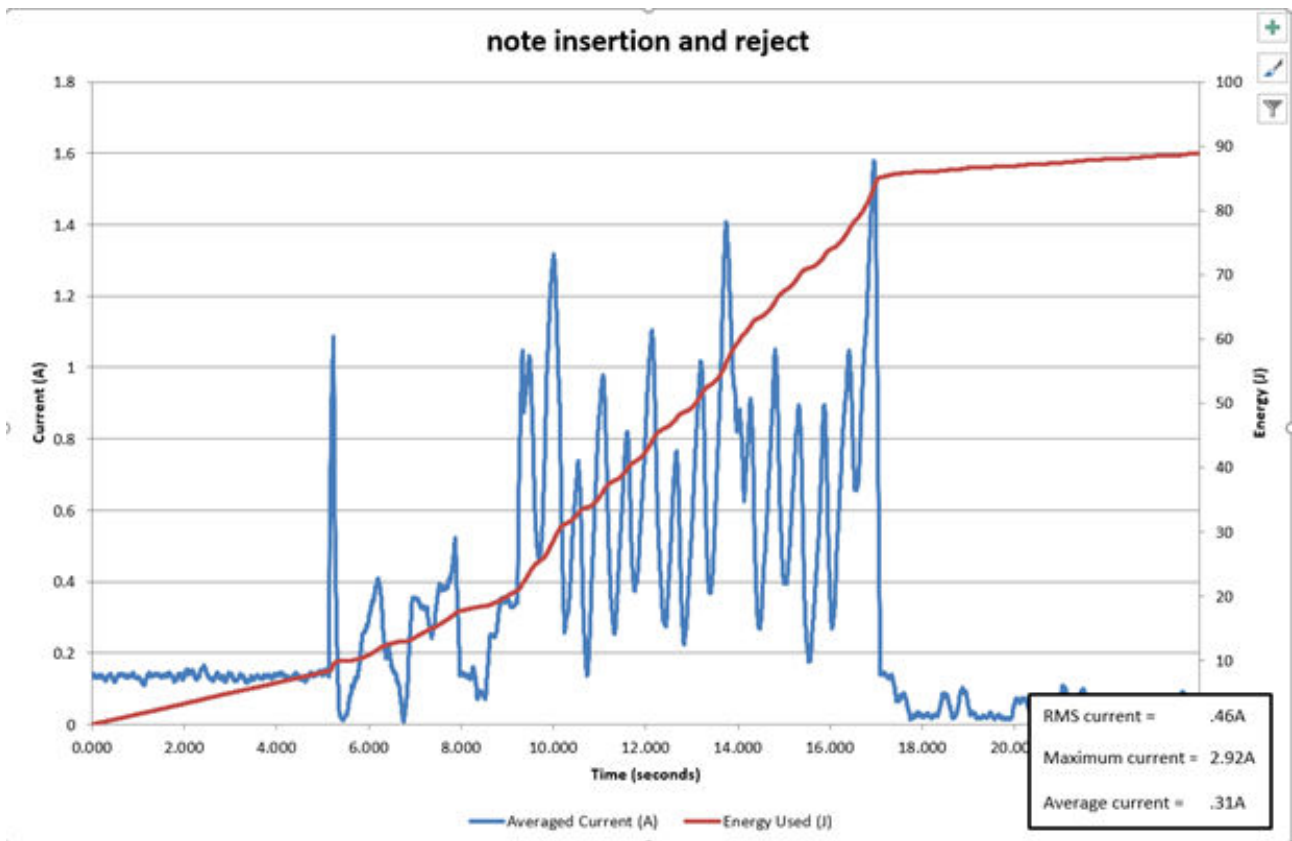

24 Volts

Power off to idle

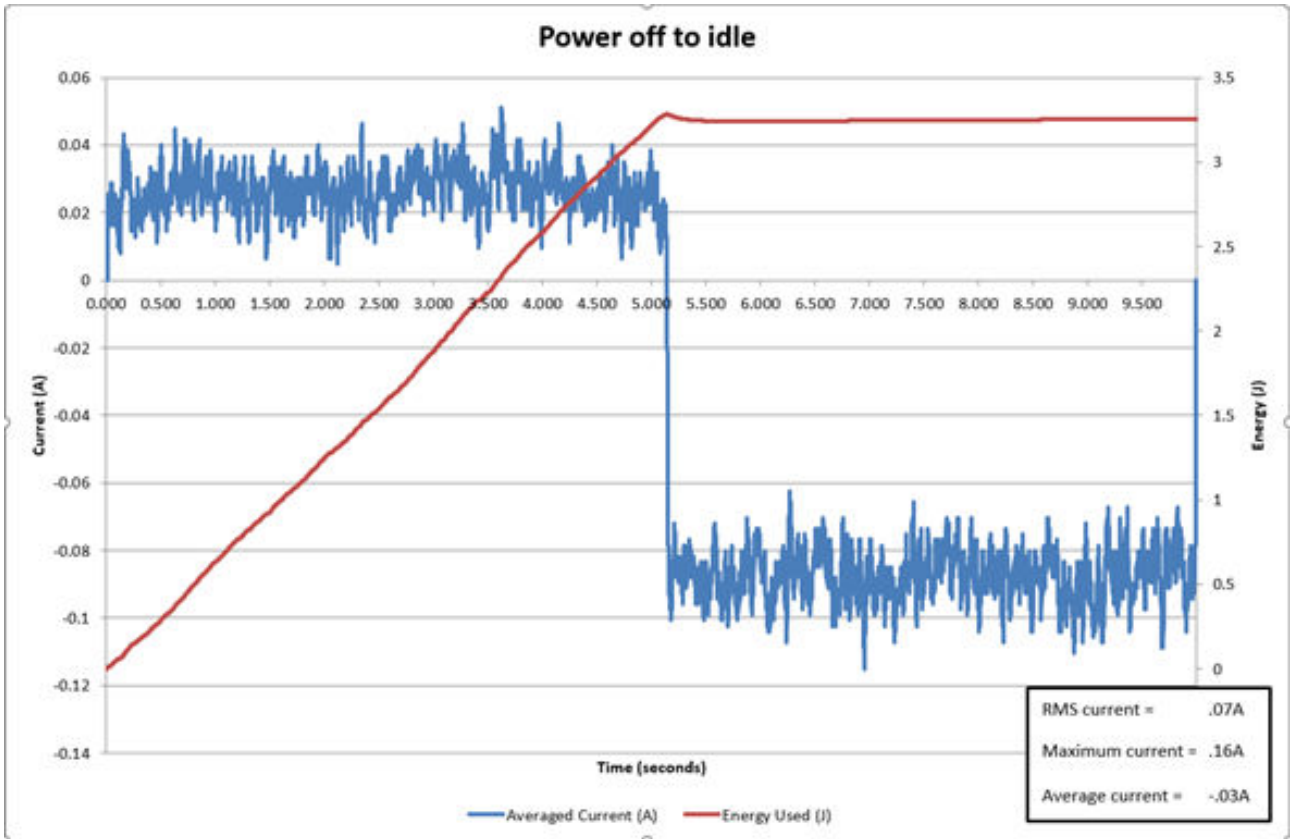

Power on to idle

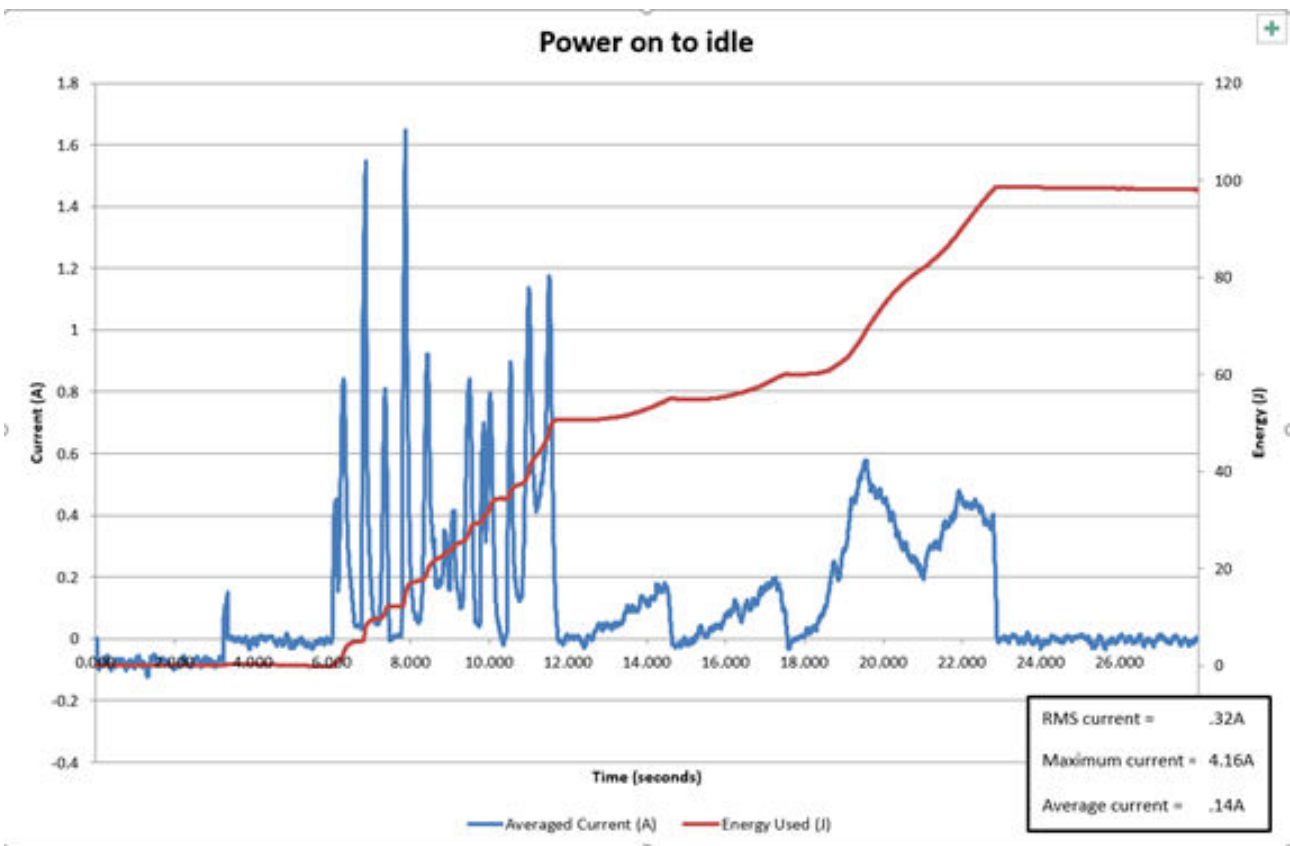

10 sec idle

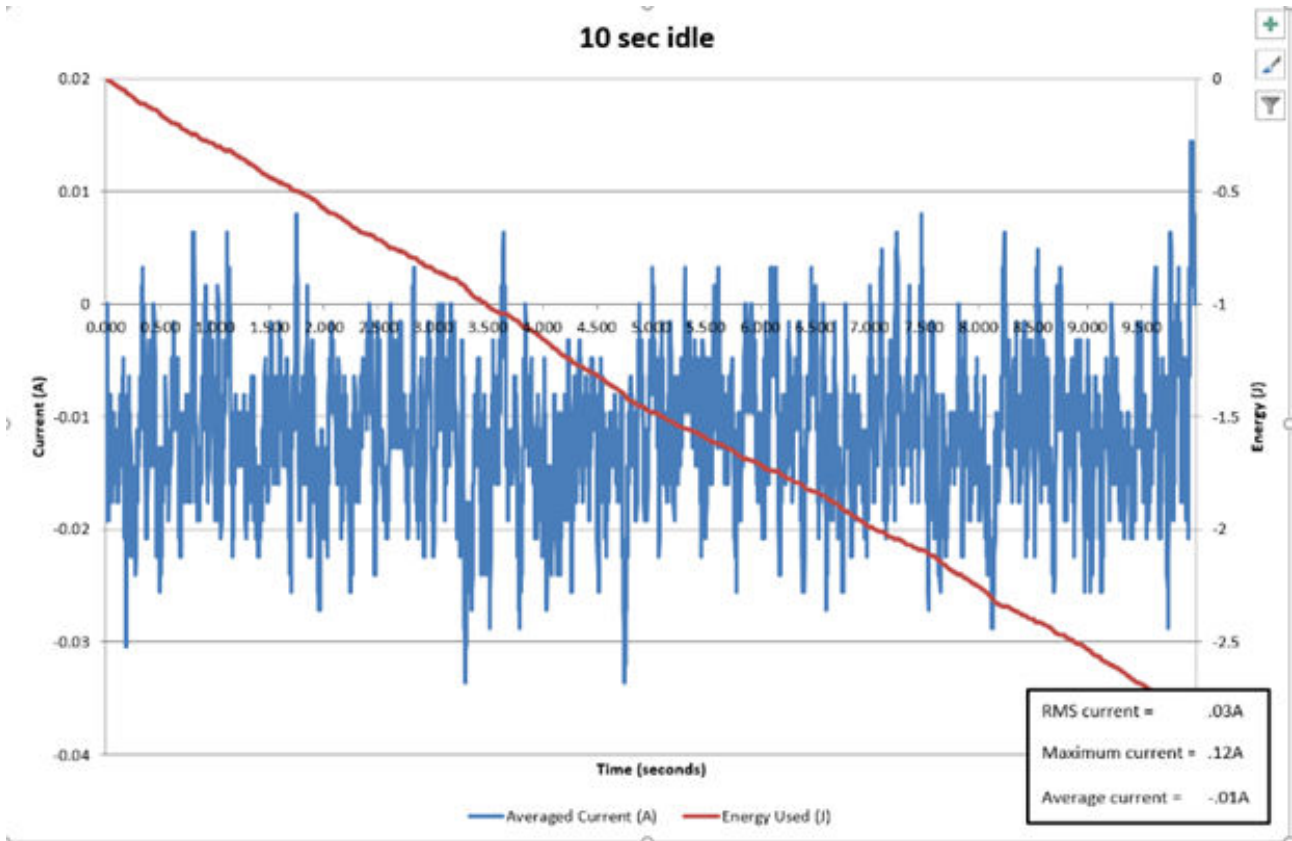

Note insert and stored

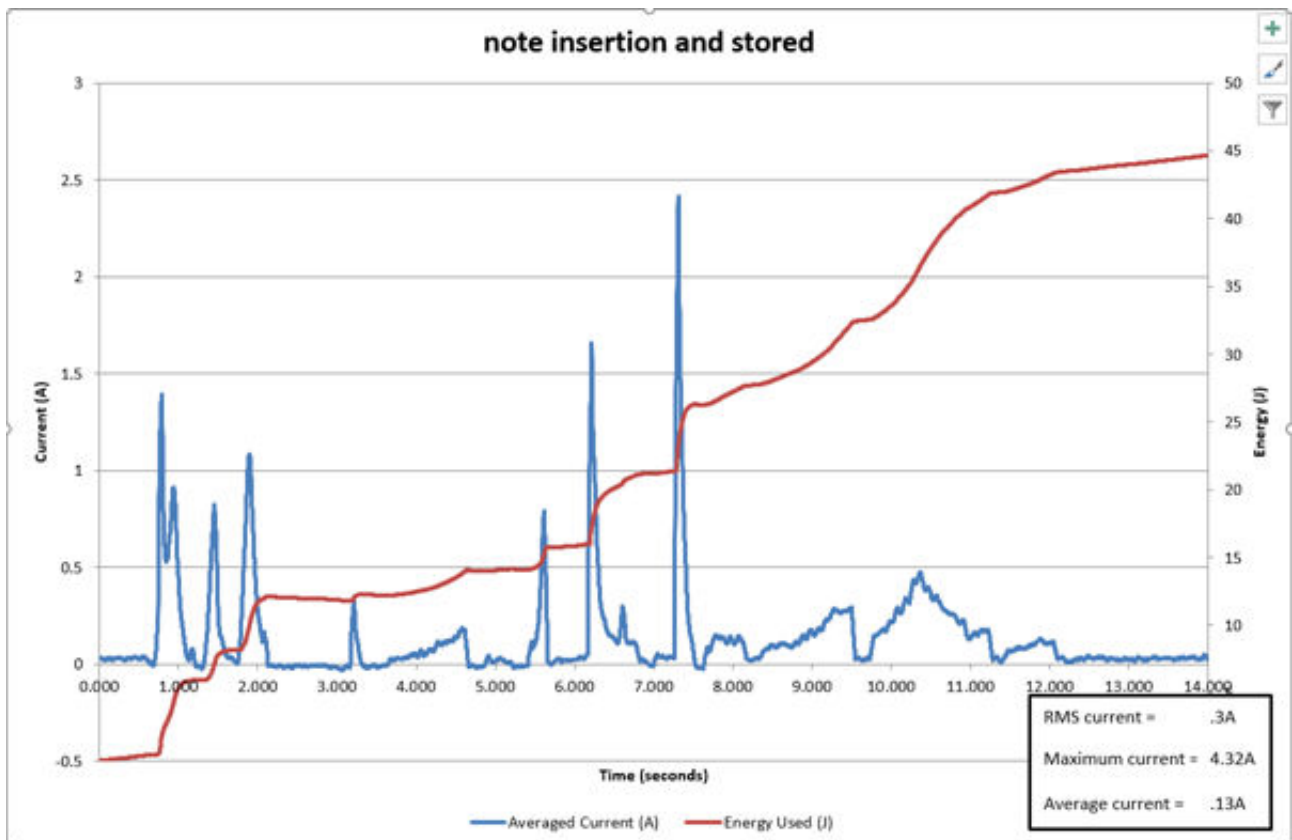

Note insert and reject

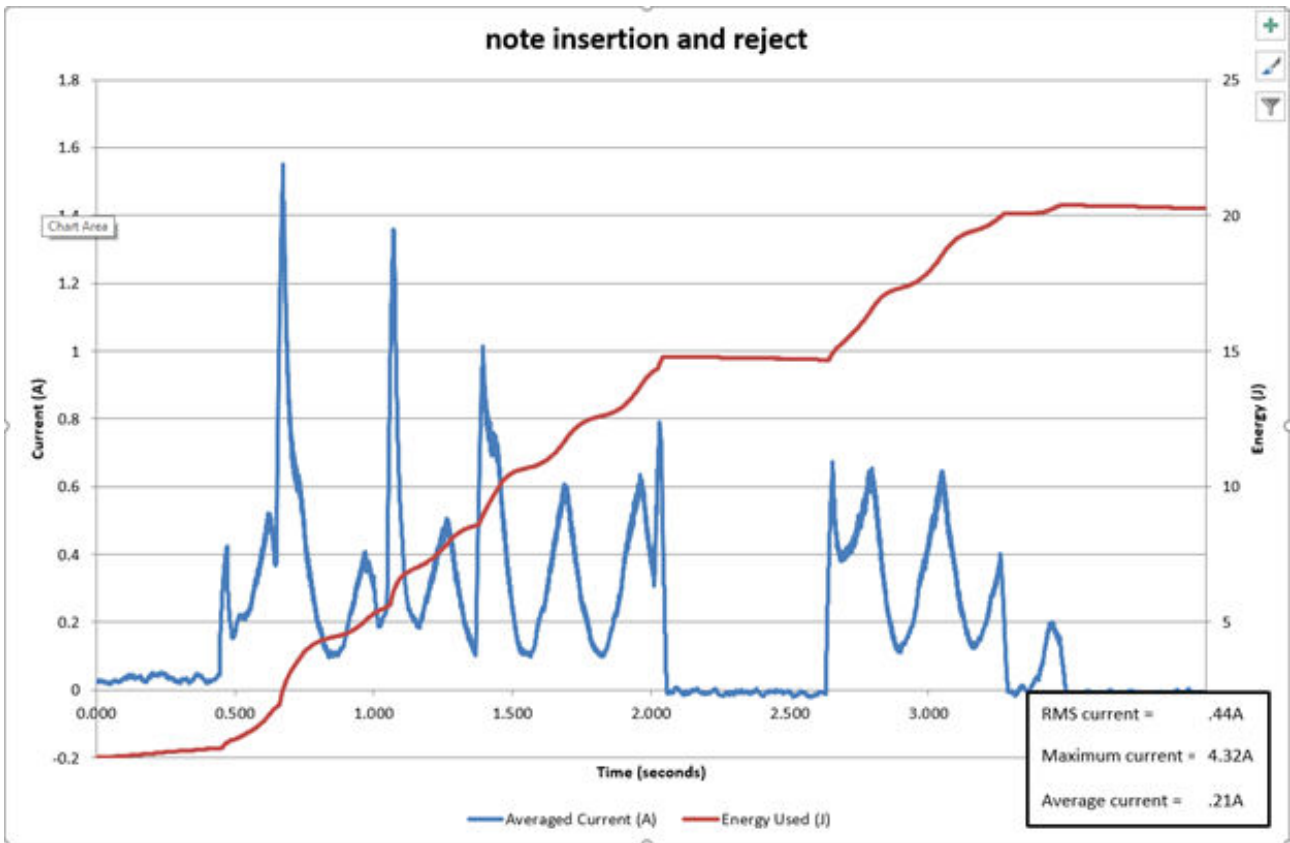

Note paid out

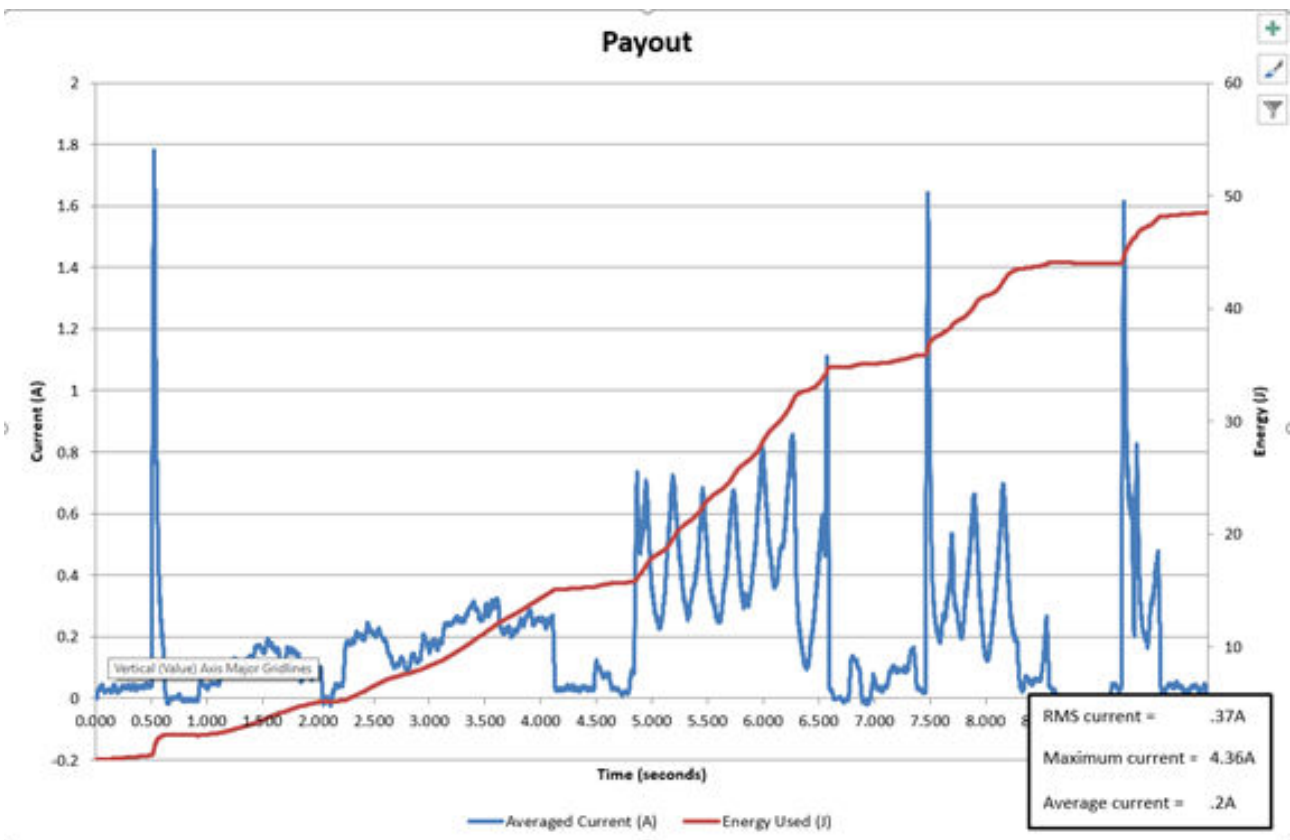

Anti-Jam Routine

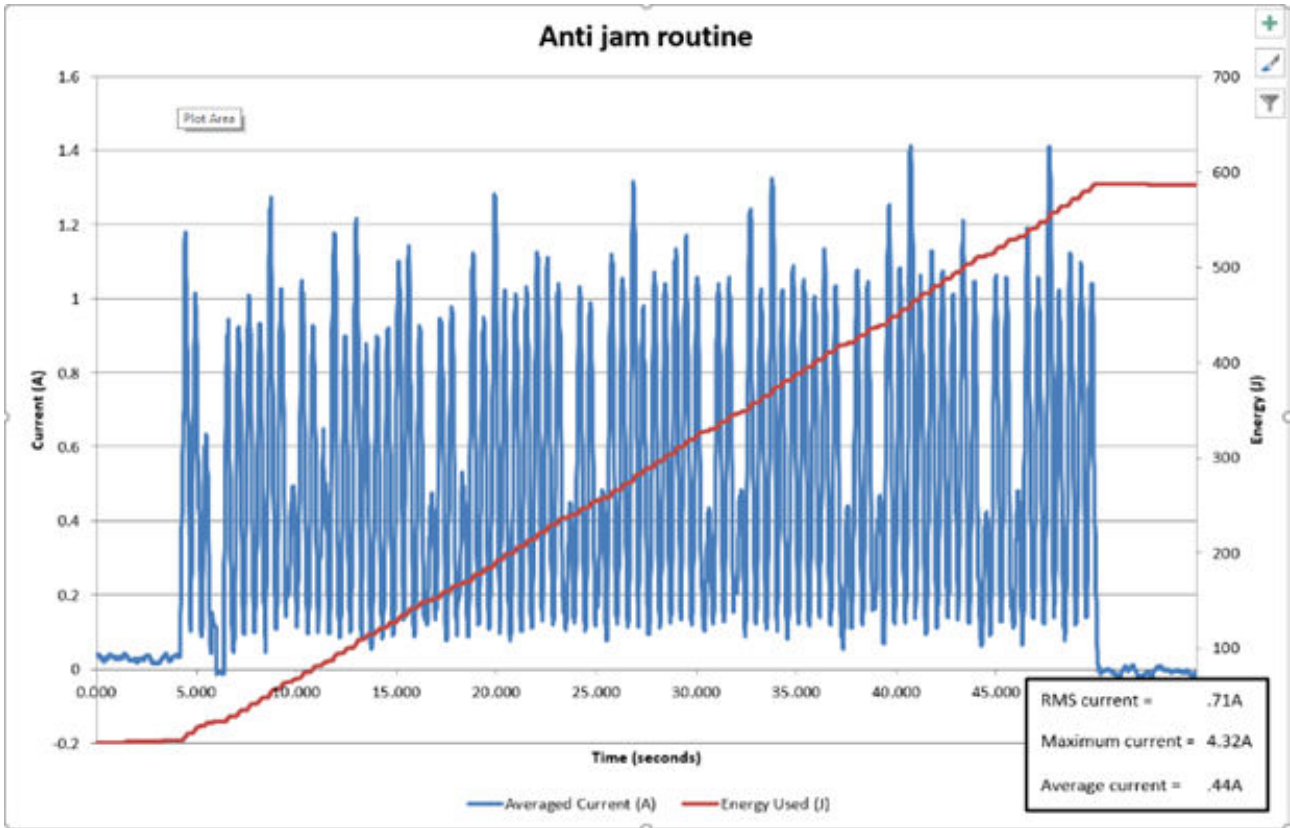

SMART Payout Jam

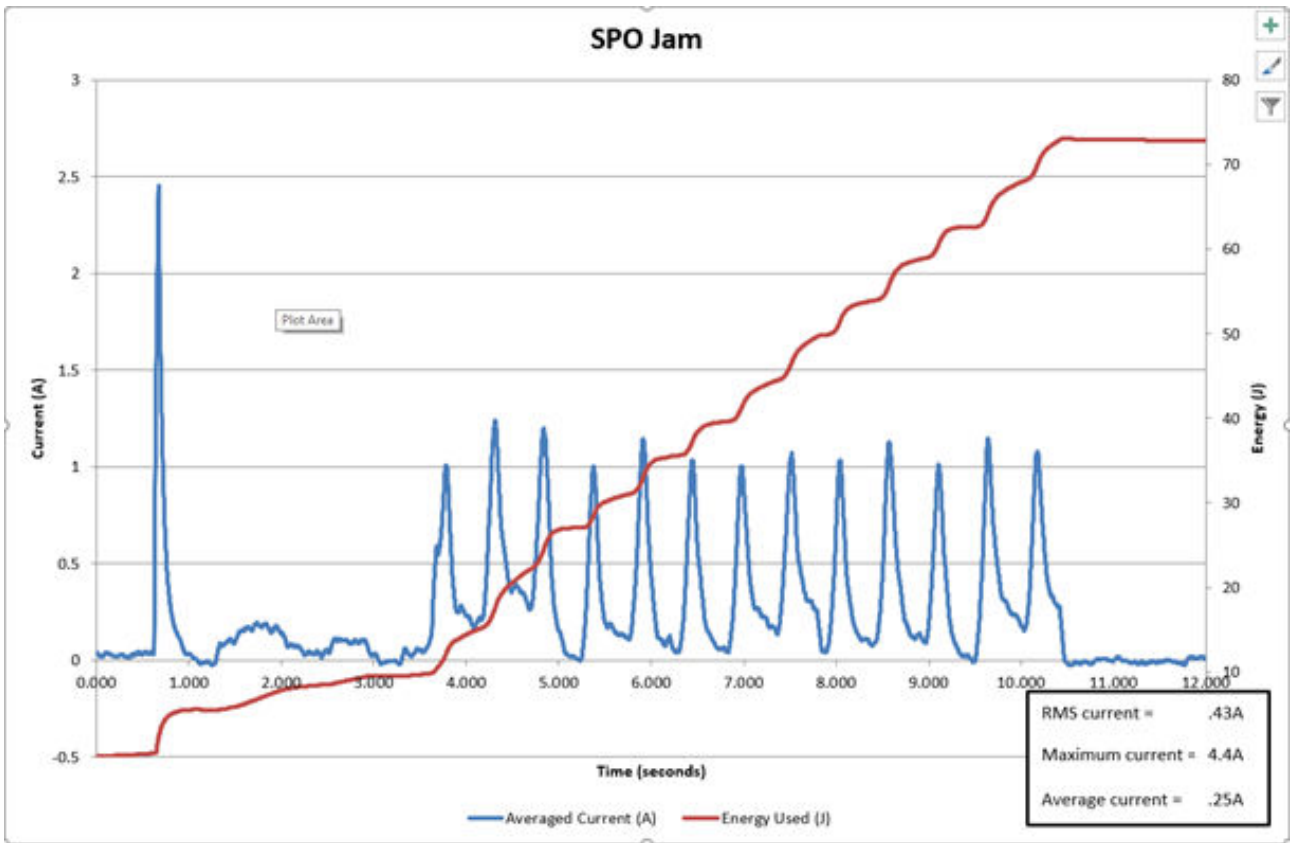

Lock Specifications

NV200 Locking Cam

DRG NO: PA650
A B

C D E F G H I J K L M N O P Q R S T

SHT 1 OF 1
U V W X

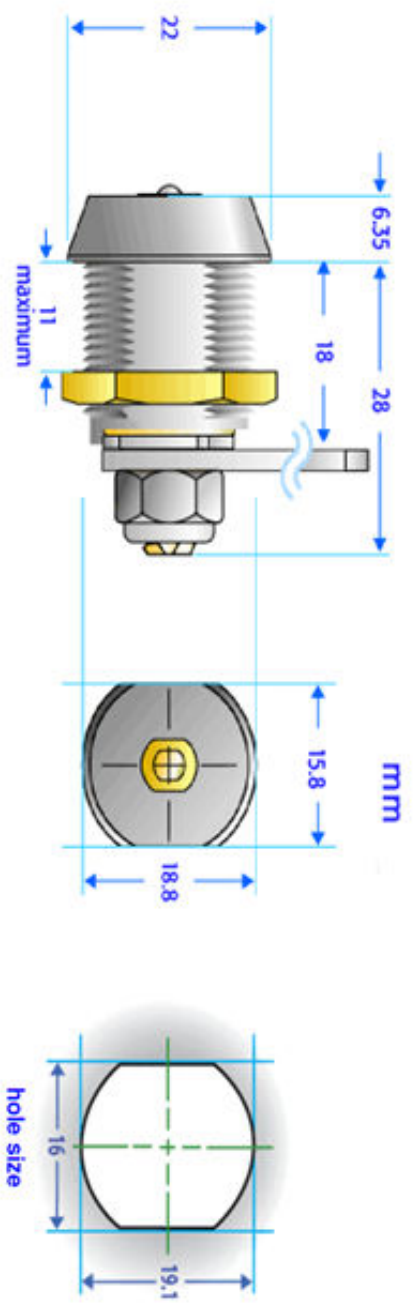

camlock part number: 28D181CPA

UNTOLERANCED DIMENSION TABLE

DIMENSION	TOLERANCE
0 - 10	±0.1
10 - 50	±0.2
50 - 100	±0.3
100 - 200	±0.5

KEY: **SC** SIGNIFICANT CHARACTERISTIC

ISSUE NO	MOD NO	DATE	MOD BY
DRAWN: _____ DATE: _____			
CHECKED: _____ DATE: _____			
TITLE: PA650 BV100 & NV200 CASHBOX LOCK			
MATERIAL: _____ FINISH: _____			
SCALE: NTS			
TOOL NO: _____			
DRG NO: _____			
ISSUE: 1			



ALL DIMENSIONS IN MM
DO NOT SCALE
FIRST ANGLE PROJECTION

SCALE: NTS

TITLE: PA650 BV100 & NV200 CASHBOX LOCK

SCALE: NTS

TOOL NO: _____

DRG NO: _____

ISSUE: 1

Cable Drawings

CN00214

PARTS LIST
CN00214
A

Parts List

Item	QTY	Description	Vendor
A	1	USB Type A Male Connector	-
B	1	USB Shielded High Speed 2.0 Cable 28AWG/1P+28AWG/2	-
C	1	USB Type B Male Connector	-

Comments

Note to Manufacturers
 Certificates are needed for the following:
 ■ RoHS compliance ■ UL94-V0 rated (connector housing) ■ UL 94-VW1 rated (all other parts)

REVISIONS

REV	DATE	DESCRIPTION	BY	CHKD
1	15/03/2013	Initial release	C. Cardoza	-
2	15/01/2012	Initial release	-	C. Cardoza

ALL DIMENSIONS ARE IN MM UNLESS SPECIFIED

NOT TO SCALE

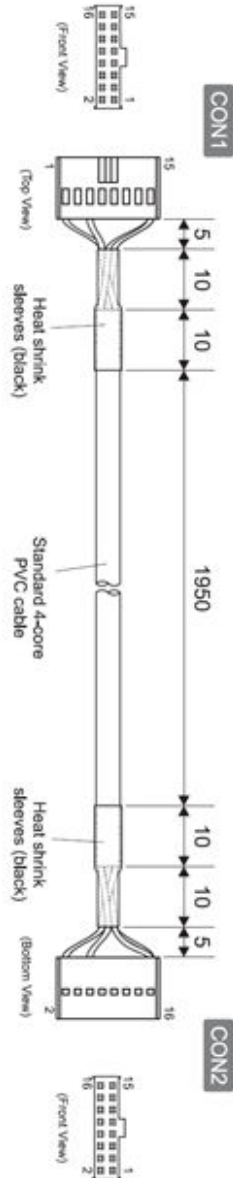

Terminal
CON1
CON2

Housing
Lelectronics 2652-2161 (2x8way 2.54mm pitch with key)
Lelectronics 2652-2161 (2x8way 2.54mm pitch with key)

Crimp
2653-2000 (in plates)
2653-2000 (in plates)

*Accepted alternatives: 90119-0110 (Molex crimps) and 90142-0016 (Molex housing)

Connectivity by conductor

CON1 Pin	CON2 Pin	Gauge (AWG)	Colour	Comments
1	1	24	Orange	-
5	5	24	Brown	-
15	15	24	Red	VIN
16	16	24	Black	GND

Note:
Pins 3,4,7,8,9,10,13 and 14 are unloaded
Pins 2,6,11 and 12 are loaded but not connected

REVISION		DATE		BY		CHECKED BY		DATE		BY	
1											
2											
3											
4	27/08/09										
5											
6											
7											
8											
9											
10											
11											
12											
13											
14											
15											
16											
17											
18											
19											
20											
21											
22											
23											
24											
25											
26											
27											
28											
29											
30											
31											

All parts must be rated to at least UL94V-0
All connector housings must be rated to UL94V-0

RECOMMENDED TERMINAL JARVIS
RECOMMENDED HOUSING JARVIS

2009 Copyright of Innoventive Technology Ltd
NOT TO SCALE
All dimensions in mm ±2mm

IF-10 - SSP to Binary Interface Cable

DESIGNED BY: A Lunsong
DATE: 27/08/09
CHECKED BY: A Lunsong

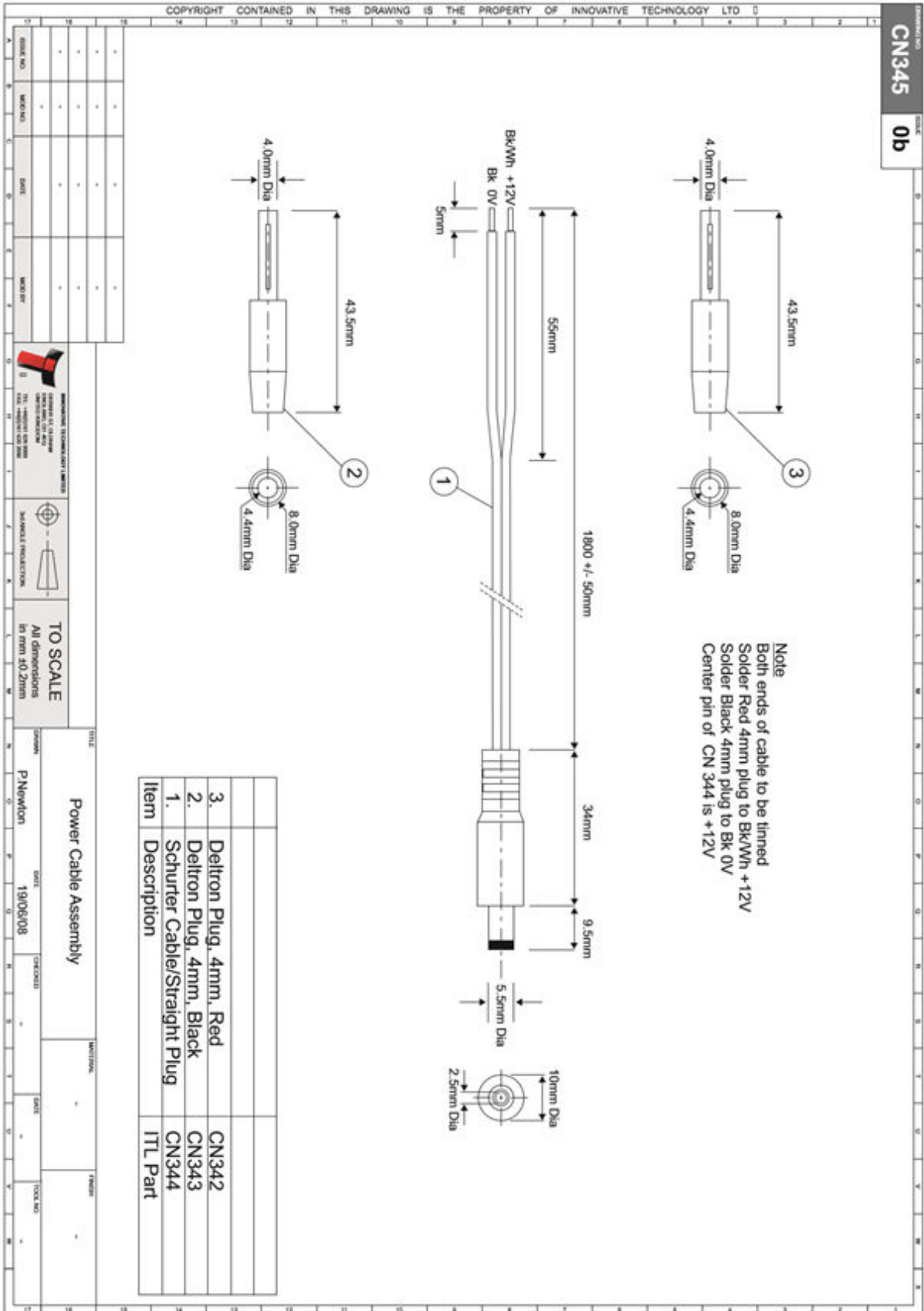

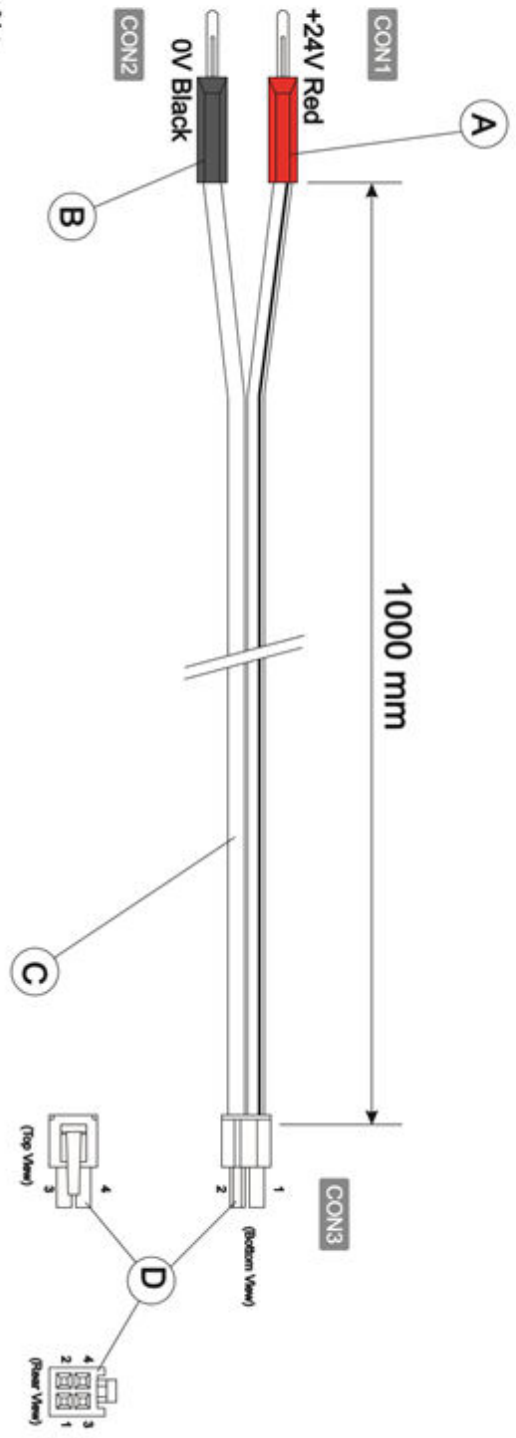

Parts List

Item	QTY	Description	Part Number	Vendor
A	1	4mm Stackable Plug, Red	553-0500-01	Deltron
B	1	4mm Stackable Plug, Black	553-0100-01	Deltron
C	1	Polarised Audio Wire, 2 x 0.5mm ² AWG 20-18	-	-
D	1	4 Circuit Receptacle Housing, 4,2mm PE Series ULL94V-2	794954-4	Tyco
E	2	4,2mm PE Series Crimp Socket (Not Shown)	1586315-1	Tyco

Connectivity

CON1	CON2	CON3	Colour	Comments
Pin 1	Pin 1	Pin 1	Black/Red	24V (Hopper Power)
Pin 2	Pin 2	Pin 2	Black	0V (Hopper GND)

Note:
 All other pin locations are empty.
 Audio wire colour is not important but polarisation marking is required.

All parts must be related to all listed ULL94-VW1

2009 © Copyright of Innovative Technology Ltd
 NOT TO SCALE
 All dimensions in mm ±2mm

Hopper Interface Power Cable

Drawn by: P Newton DATE: 14/05/2009

Checked by: DATE: PART: TOOL NO:

All Materials used must be RoHS Compliant

REV	DATE	BY	REASON
1	04/01/10	P Newton	Production
2	28/02/2011	P Newton	Production

COMMERCIAL
CN398
 COIL 1

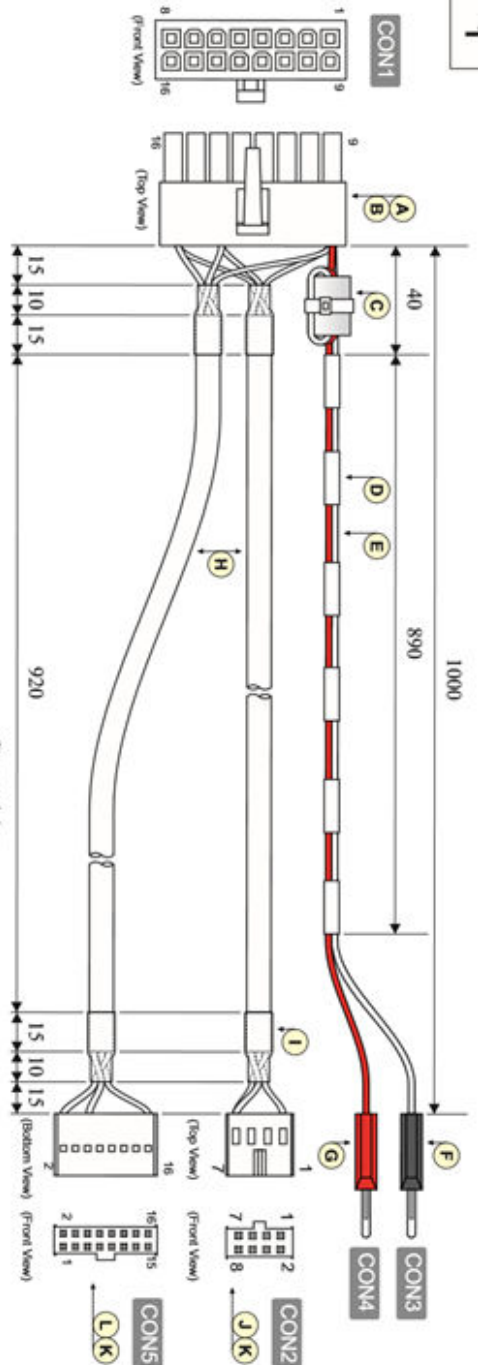

Parts List

Item	QTY	Description	Vendor
A	1	0039012165 housing (2x8way 4.2mm pitch Mini-Fit receptacle)	Molex
B	4	0039000038 tin plated, female crimp (10-13-165082160-0 (K5A T 16.5x8.2x16 toroidal core)	Molex
C	1	(2 turns (1 loop); cable tie to secure in place)	Paddiford Electronics/ Z-Shen Enterprise
D	10	15mm long, black heat shrink sleeve (spread along the length of harness with typical separation of 82mm)	-
E	2	Standard 22AWG wire	-
F	1	553-0100-01 stackable black 4mm banana plug	Deltron
G	1	553-0500-01 stackable red 4mm banana plug	Deltron
H	2	4-core AWM style 2462 24AWG cable	-
I	4	25mm long, black heat shrink sleeve	-
J	1	90142-0008 housing (2x4way 2.54mm pitch with key)	Molex
K	8	9733272 tin plated crimp	Molex
L	1	90142-0016 housing (2x8way 2.54mm pitch with key)	Molex

Connectivity

CON1 Pin	CON2 Pin	CON3 Pin	CON4 Pin	CON5 Pin	Gauge (AWG)	Colour	Comments
16	7	-	1	1	24	Orange	SSP TX (Vend1)
14	8	-	5	5	24	Brown	SSP RX (Inhibit)
9	-	-	1	-	22	Red	V_IN (12V)
1	2	1	-	16	24/22	Black	GND

Note:
 Pin 14 and 16 (CON1) each has two wires crimped together.
 Pin 1 (CON1) has three wires crimped together. If crimp is unable to hold three wires together please use AWG 26 for the 4-core PVC cable.
 Pin 1 (CON2) is fitted with crimp but not connected.
 Pin 15 (CON5) is fitted with crimp but not connected.
 All other pins are unloaded.
 For the unused wire in the 4-core PVC cable, please trim excess or, if possible, please use a 3-core PVC cable.
 Length for both PVC cable is the same.

Host machine (via CON5) controls both Hopper and Payout through different SSP addresses. Hence, SSP_TXD_Vend1 on Payout and SSP_TX on Hopper are both linked to pin 1 (Vend1) on CON5.

Comments
 CON1 mates with 6745-2160 straight header (on Smart Payout)
 CON2 connects to SSP Hopper Interface Port
 CON3 connects to V_ (GND) of power supply
 CON4 connects to V+ (12V) of power supply
 CON5 connects to Host Machine

All parts must be rated to at least UL94-VW1		All connector housings must be rated to UL94-V0		2009 © Copyright of Innovative Technology Ltd	
All dimensions in mm		All dimensions in mm		NOT TO SCALE	
Dual ESSP interface to both Smart Payout and Hopper assembly		A Lunsong		15/09/09	

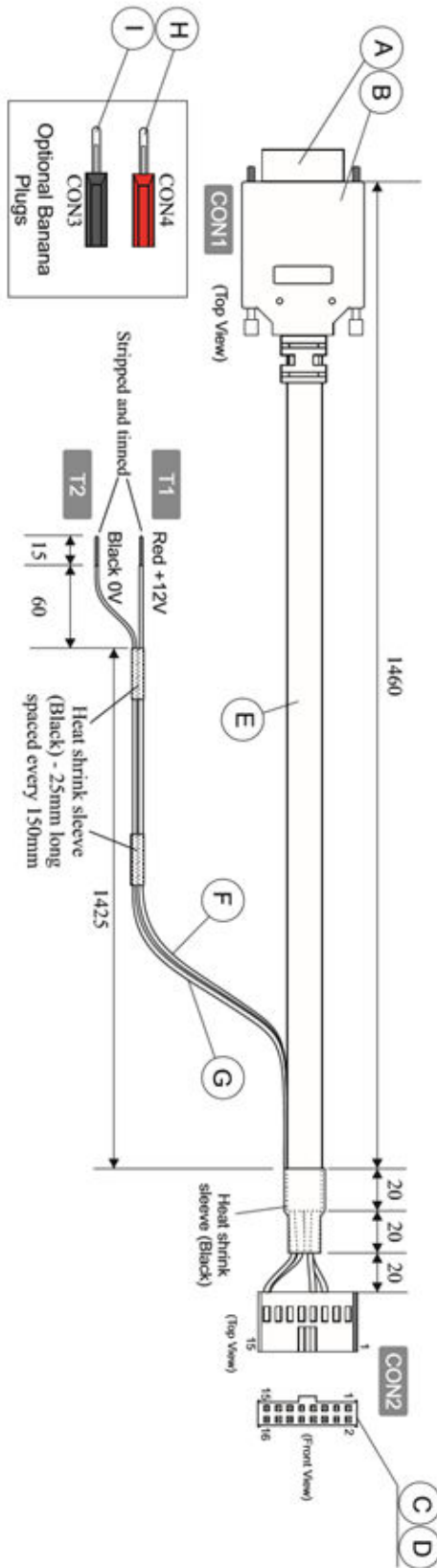

Item	Description
A	MULTICOMP - 5501-09SA-02-F1, SOCKET, D, SOLDER, 9WAY (Farnell 10844678)
B	MH CONNECTORS DPPK9-BLACK-K, D-Sub Shell, Plastic, 9 Way (Farnell 469-889)
C	MOLEX 9733272, Crimp (tin plated)
D	MOLEX 90142-0016, (2x8way 2.54mm pitch with key)
E	Use 3 or 4 core AWM Style 2464 24AWG Cable, as available (Cut away any unused wires).
F	Red Cable rated to UL1007
G	Black Cable rated to UL1007
H	DELTRON 553-0500-01, Stackable Red 4mm banana plug (Optional).
I	DELTRON 553-0100-01, Stackable Black 4mm banana plug (Optional).

Connectivity by conductor

CON1 Pin	CON2 Pin	CON3 Pin	CON4 Pin	Gauge (AWG)	Colour	Comments
2	6	-	-	24	Brown	RX(DTE-DCE)
5	16	-	-	24	Black	GND
3	7	-	-	24	Orange	TX(DTE-DCE)
-	16	1	-	22	Black	GND
-	15	-	1	22	Red	12V

Note:
 All other pins are unloaded.
 CON2,16 loaded with two wires in one crimp.

- Comments**
 CON1 Connects with Host
 CON2 Connects to Validator
 T1 Connects to 12V Power Supply
 T2 Connects to 0V(GND) of Power Supply

REV	DATE	DESCRIPTION	BY	CHKD	APP'D
1	04/03/2010	P/Newton			

REV	DATE	DESCRIPTION	BY	CHKD	APP'D
1	04/03/2010	P/Newton			

REV	DATE	DESCRIPTION	BY	CHKD	APP'D
1	04/03/2010	P/Newton			

CN487 **C3**

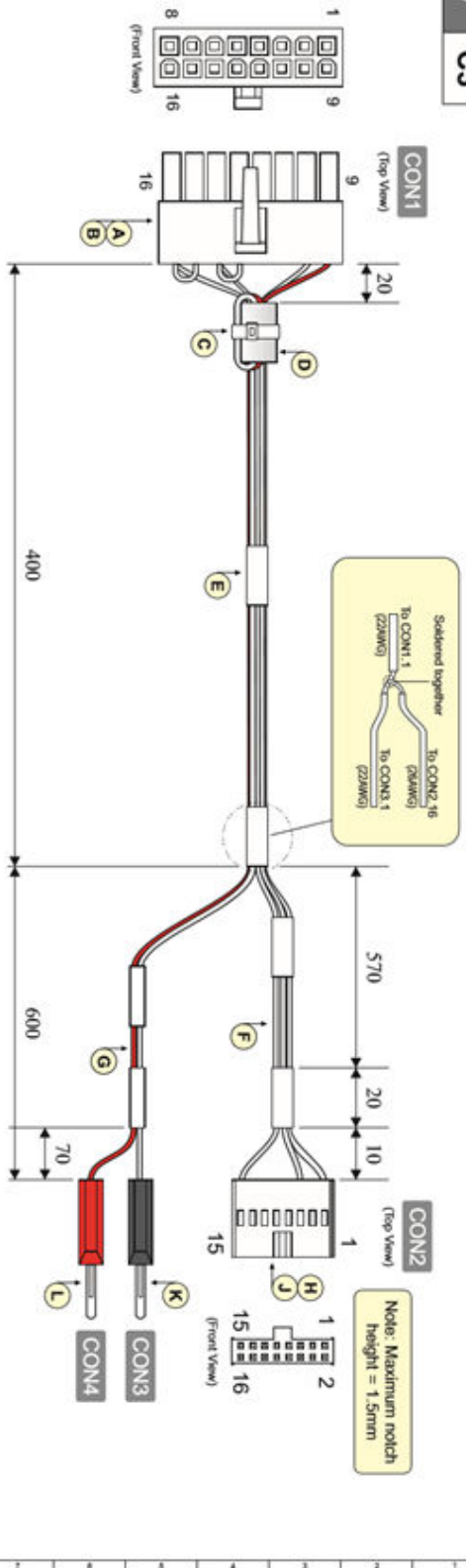

Item	QTY	Description	Vendor
A	1	39-01-2165 housing	Mokox
B	6	(2x 8 way 4.2mm pitch Mini-Fit Jr receptacle) 0038000209 (tin plated, female, brass) crimps (4A @ 22AWG, 2A@25AWG)	Mokox
C	1	Cable tie to secure ferrite into place	-
D	1	Ferrite (2 turns)	-
E	6	20mm black heat shrink sleeve (opened along the length)	-
F	5	Standard AMG 26 wire (see comments below)	-
G	1	Standard AMG 22 wire	-
H	1	90142-0016 housing	Mokox
J	3	(2x) 2way 2.54mm pitch receptacle) 90119-0120 (tin plated) crimps	Mokox
K	1	Stackable black 4mm banana plug (SS3-0500-01)	Deltron
L	1	Stackable red 4mm banana plug (SS3-0500-01)	Deltron

Connectivity	Ferrite	CON2	CON3	CON4	Gauge (AWG)	Colour	Comment
CON1	1 loop	Pin	Pin	Pin	26	White	SSP_TXD (Validator to Host)
	16	1	-	-	26	Blue	SSP_RXD (Host to Validator)
	14, 5	14	-	1	22	Red	V_IN
	9	9	-	1	22	Black	GND
	1	1	16	-	-	-	-

Notes
 Plus 16 and 7 on CON1 are linked together.
 Plus 14 and 5 on CON1 are linked together.

Ferrite Sleeve
 Ferrite sleeve needs to have >S72D @ 100MHz.
 Recommended parts:
 a) Wurth 74270060 - 714D @ 100MHz (two turns)
 b) Edgier FL8 FH10 x 20 x 6.35 - 724D @ 100MHz (two turns)



Comments
 CON1 connects to Smart Ticket
 CON2 connects to Host
 CON3 connects to V- (GND)
 CON4 connects to V+ (12V or 24V)

For item F, 2 wires are short links for pins 16 and 7 and pins 14 and 5 on CON1; 2 wires are from CON1 to CON2; and 1 wire is from CON2 to the soldered interconnection.
 CON3 and CON4 are for powering up the NV200 so V+ can be connected to 12V or 24V

Note to Manufacturers

Certificates are needed for the following:
 RoHS compliance U.L94-V0 rated (connector housing) U.L94-VW1 rated (all other parts)

	TITLE Smart Ticket/Payout to Host assembly (customer)	DATE 31/01/2012	DATE 31/01/2012	CHECKED BY A Lunsong	DATE 31/01/2012
APPROVED BY A Lunsong		APPROVED BY A Lunsong		APPROVED BY A Lunsong	

All dimensions are in mm 55mm, unless specified

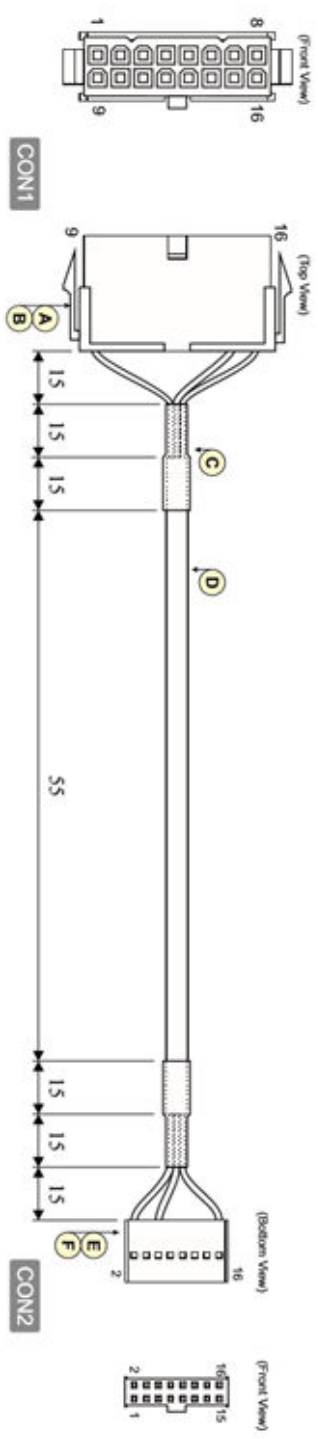

Parts List

Item	QTY	Description	Vendor
A	1	0039012166 plug housing (2x8way 4.2mm pitch Mini-Fit Jr)	Molex
B	4	0039000126 male crimp (phosphor bronze, tin plated, 18-24AWG)	Molex
C	2	30mm long, black heat shrink sleeve	-
D	1	4-core AWM style 2462 22AWG cable	Molex
E	1	90142-00116 housing (2x8way 2.54mm pitch with key)	Molex
F	4	9733272 tin plated crimp	Molex

Connectivity

Pin	CON1	CON2	Gauge (AWG)	Colour	Comments
1	1	24	24	White	SSP_TXD_(Vend1)
16	1	24	24	Green	SSP_RXD_(Inhibit)
14	5	24	24	Green	SSP_RXD_(Inhibit)
9	15	22	22	Red	V_IN
1	16	24/22	24/22	Black	GND

Note to Manufacturers
 Certificates are needed for the following:
 ■ RoHS compliance ■ UL94-V0 rated (connector housing) ■ UL94-VW1 rated (all other parts)



Smart Payout to NV200 adapter harness

DESIGNED BY: A Lunsong
 DATE: 02/10/12

REVISIONS:
 A1
 DATE: 02/10/12

All dimensions are in mm ±50µm, unless specified

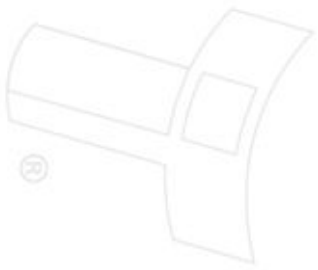

Switching to Programming Mode (SSP)

If fitted remove the Payout or Ticket modules. Power the NV200, once the unit has initialised toggle **dip-switch 8** up and down.

To switch the unit back repeat the procedure explained above.



When in programming mode and performing an update, do not turn off the power before the operation is complete as this could make the unit unusable.

Changing the Cashbox Flag in the NV200

If the NV200 is configured for the wrong cashbox this is changed using validator manager. Navigate to the 'Options' tab, select Cashbox Type from the right hand side and select the appropriate cashbox from the dropdown. Click apply changes; the unit will reset with the applicable cashbox setting.

Freefall Cashbox Advice

The NV200 cashbox and TEBS cash bag have been designed to remain intact after an impact of 75cm onto a concrete floor. Dropping the cashbox multiple times can result in physical damage to the cashbox/bag.

ccTalk DES Encryption - Trusted Mode

Ensure the NV200 has been configured to use DES encryption in Validator Manager, this setting can be found on the options tab. To pair the NV200 with a DES trusted machine please follow the steps below:

1. Remove power from the unit then remove the cashbox
2. Re-power the unit, once the unit has started it should be in pairing mode.



If a Smart Payout module is connected the unit must be empty before it can pair to the host.

Escrow

The NV200 has a single note escrow facility. This allows the NV200 to hold onto the note once validated, and only stack the note into a cashbox when the host machine confirms that the Vend operation has been completed. If no confirmation of the Vend is received, the note will be returned to the user after 30 seconds. If the host machine itself aborts the transaction by sending the reject command (0x08). Similar commands can be sent depending on the protocol used. For information relating to other protocols please contact support.

Multi-Escrow

When the Payout module is used it adds the ability to store up-to 20 notes in escrow, this is done by dynamically allocating certain positions on the tape to escrow.

As slots are assigned dynamically it means when the transaction is completed notes don't need to move to a different location thus the speed of the unit isn't affected.

For more details on the multi-escrow functionality please contact our support team.

File Naming Convention

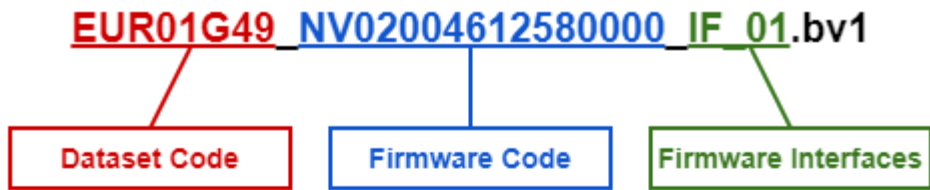

Dataset Code

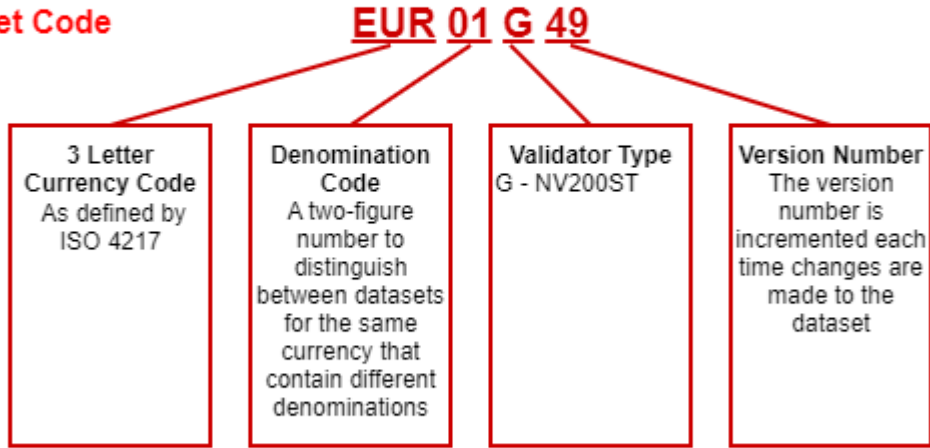

Firmware Code



Firmware Interfaces

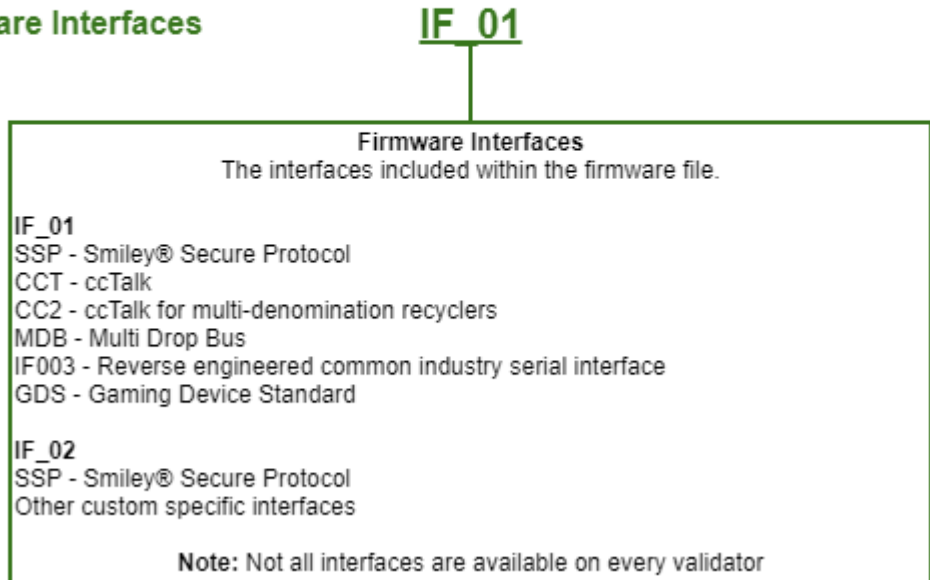

NV200 Range Disclaimer and Safety Information

Contents

- [Disclaimer](#)
- [Product Safety Information](#)

Disclaimer

Innovative Technology:

- Is not responsible for any loss, harm, or damage caused by the installation and use of this product. This does not affect your local statutory rights. If in doubt, contact Innovative Technology for details of any changes.
- Has a policy of continual product improvement. As a result, the products supplied may vary from the specification described here.
- Does not accept liability for any errors or omissions contained within this document. Innovative Technology shall not incur any penalties arising out of the adherence to, interpretation of, or reliance on, this standard.



The contents of this manual set may be subject to change without prior notice.

Product Safety Information



Throughout this user manual, attention should be drawn to key safety points when using or maintaining the product.

These safety points will be highlighted in a box:



This is an example text.

This user manual and the information it contains is only applicable to the model stated on the front cover and must not be used with any other model.

 Danger!	IR and UV Radiation
 	<ul style="list-style-type: none">• Possible skin or eye damage due to presence of IR and UV radiation internally. Disconnect power before servicing• Use PPE measures• Follow safety precautions given in IEC 62471