



Innovative Technology

POWERING TRANSACTIONS AND INTERACTIONS

NV22 Spectral

"Compact, mixed note recycler"

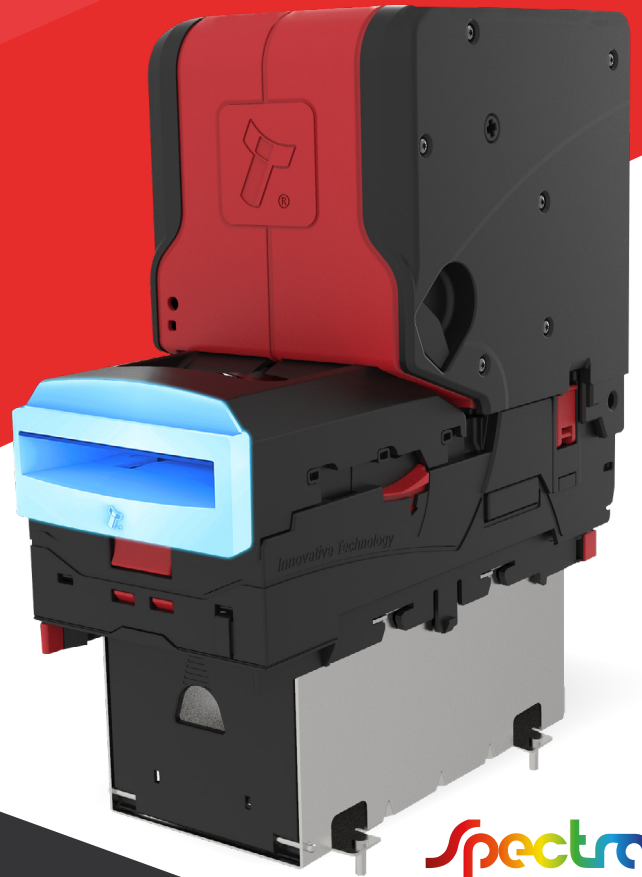

- Mixed denomination compact note recycler
- Significantly reduces operational costs
- Maximises operational efficiency and up-time
- Full note high resolution imaging



FEATURES

- 40 note mixed denomination recycler
- Spectral sensors provide full note high resolution imaging - 1.28 million datapoints
- Optical & mechanical anti-strimming technology
- Dramatically reduces coin float levels
- Easy maintenance, free firmware updates, SD card for data logging
- All mixed notes in the Multi-Note Float can be transferred to the cashbox for easy collection



BENEFITS

- Large capacity maximises cash efficiency and up-time, reducing coin starvation
- Unrivalled genuine note detection & protection against fraudulent notes
- Outstanding fraud protection
- Significantly lowers operational costs
- Future proof - quick & easy updates via USB, PC or handheld programmer
- Lowest operator collection costs



Innovative Technology

POWERING TRANSACTIONS AND INTERACTIONS

Technical Specification

Power

Requirements: 12 /24 V
Standby: 250mA
Running: 1A
Peak: 3A

Protocols

SSP
ccTalk

MCBF

100,000

Interfaces

USB
Open Collector

Note Dimensions

Width: 60 - 82 mm
Length: 115 - 150 mm

Recycler Capacity

40 mixed notes

Bezel Options

82mm horizontal
82mm chamfered
Rainbow illumination

Cashbox Options

300 standard
300 lockable
300 / 600 slide

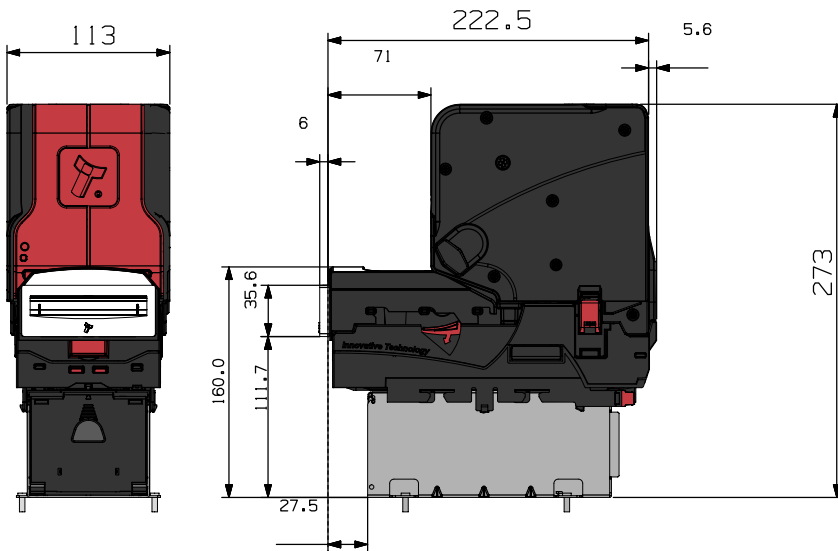

- Weight: 2.6kg

**VIEW MORE
NOTE HANDLING
PRODUCTS >>**



Find Us

Head Office

Innovative Technology Ltd (UK)
Innovative Business Park
Derker Street
Oldham
OL1 4EQ



Telephone

+44 (0) 161 626 9999



Email

sales@innovative-technology.com